



Garaventa Elevators

ELVORON LU/LA DESIGN AND PLANNING GUIDE

Limited Use / Limited Application Elevator



Table of Contents

What is a LU/LA Elevator?	3
Design Assistance	3
Finishes.....	4
How it works.....	5
Hoistway.....	6
Construction of Pit:.....	7
Overhead Clearance (Refuge Space).....	7
Pit Lighting.....	7
Loading Diagram.....	8
Car Sizes & Configurations	9
Operating Controls	10
Car Operating Panel (COP).....	10
Hall Stations	10
Car Direction Lantern.....	10
Doors - Entrance and Car Doors	11
Door Details – Masonry Walls	12
Door Details – Wood and Drywall Walls	13
Layouts & Clearances	14
Technical Information	16
Machine Room Requirements.....	19
Machine Room Layouts.....	20
Mains Power Requirements	21

Garaventa Lift: Creating an Accessible World.

Garaventa Lift has been dedicated to developing safe and reliable accessibility solutions since 1978 and is now an industry leader worldwide. Years of hard work and an uncompromising commitment to quality have enabled us to perfect the internationally renowned Garaventa GSL Artira and Xpress II Inclined Platform Lifts, the Genesis Vertical Platform Lift, the Elvoron HR Residential Elevator, the Elvoron CPL (Commercial Platform Lift) and the Elvoron LU/LA Elevator. At Garaventa Lift we strive to incorporate state of the art features with elegant styling and quiet operation in all of our products.

The Elvoron LU/LA has a variety of models and configurations with many standard features and optional features to choose from. With the addition of the Elvoron product line, Garaventa Lift has taken a significant step towards being able to solve all accessibility challenges for building owners.

Our expertise in providing solutions has enabled our design team to take on the most challenging situations and develop innovative solutions for schools, places of worship, offices, hotels, airports, subways and a wide range of public and private buildings around the world.

We have built our business on service. Please contact us and let us help solve your challenges.



Creating an Accessible World

© Garaventa Lift 2011

*As we are continuously improving our products,
Specifications outlined in this guide are subject to change without notice.*

What is a LU/LA Elevator?

The Elvoron LU/LA (Limited Use Limited Application) elevator is a cost effective way to transport the public from one landing to another. A LU/LA elevator is a power passenger elevator in which the use and application is limited by size, capacity, speed and rise. The Elvoron LU/LA elevator provides a code compliant automatic elevator with a variety of platform configurations and can service up to 6 landings. The wide selection of cab finishes and options ensure that it will blend into any setting.

What is Limited about a LU/LA elevator?

- Travel – 25 feet (7.6 meters) (check the regulations for your jurisdiction)
- Speed –30 fpm (0.15 m/sec) nominal
- Maximum Platform Size – 18 square feet (1.67 square meters)
- Maximum Capacity – 1400 lbs (635 Kg)

Why a LU/LA Elevator?

Cost Effective

LU/LA elevators are much more cost effective than a regular passenger elevator.

Application

The LU/LA elevator is intended to be used in low rise buildings with low occupancy, where a full passenger elevator is not required. Its' application in buildings is self limiting due to the restricted travel, speed, capacity and size.

Meets ADA Requirements (USA)

The Elvoron LU/LA elevator meets the requirements of the Americans with Disabilities Act and most other Accessibility Codes and Requirements.

Design Assistance

With over 35 years of experience, Garaventa Lift has the expertise to overcome almost any design challenge you face. Please call our Design Hotline.

1-800-663-6556 or 1-604-594-0422

Finishes

Your Elvora elevator will be a key feature in your building. Interior design and finish are important considerations. We offer a variety of attractive and durable wall and ceiling finishes. If you're looking for something a little different, our custom shop can design an elevator to fit your vision. All Elvora cars are supplied with basic plywood floors ready for installation of your preferred flooring material, as supplied by others.

Car Walls covered in Laminate Panel Sections – Fire rated, tough, easy to clean and offered in a choice of 8 standard colors.

- Designer White
- Dove Grey
- Cloud Nebula
- North Sea
- Kensington Maple
- Oregon Oak
- Grey
- Empire Mahogany

Car Wall Trim separates the car wall panels and adds the finishing touch to your elevator cab. The standard trim is available in black or white. Custom colors and stainless steel trims are optional.

Entrance Door and Car Doors – Like a commercial elevator, the Elvora LU/LA is equipped with two-speed horizontal sliding landing entrances and car doors. The car doors are finished to match your car wall trim. The landing entrance doors are primed and ready to be painted to match your building décor. All doors can be supplied in brushed stainless steel.

Ceiling and Halogen Lighting – All Elvora LU/LA's are equipped with four recessed low-voltage halogen lamps that illuminate automatically when the doors open. Ceiling choices are white, stainless steel or custom. White lamps are fitted into white ceiling and black into stainless steel ceilings.

Custom Car Finishes – Your car interior can be customized to whatever unique design best suits your building project. Our custom shop offers a wide variety of wall, ceiling and fixture alternatives. We can also create elegant stainless steel and glass cars (panoramic).

Handrail – All Elvora cars are equipped with one handrail on the control wall. Additional handrails can be mounted on the other car walls. The handrails are available in three standard finishes or can be customized.

- Stainless Steel
- Brass
- Antique Brass

How it works

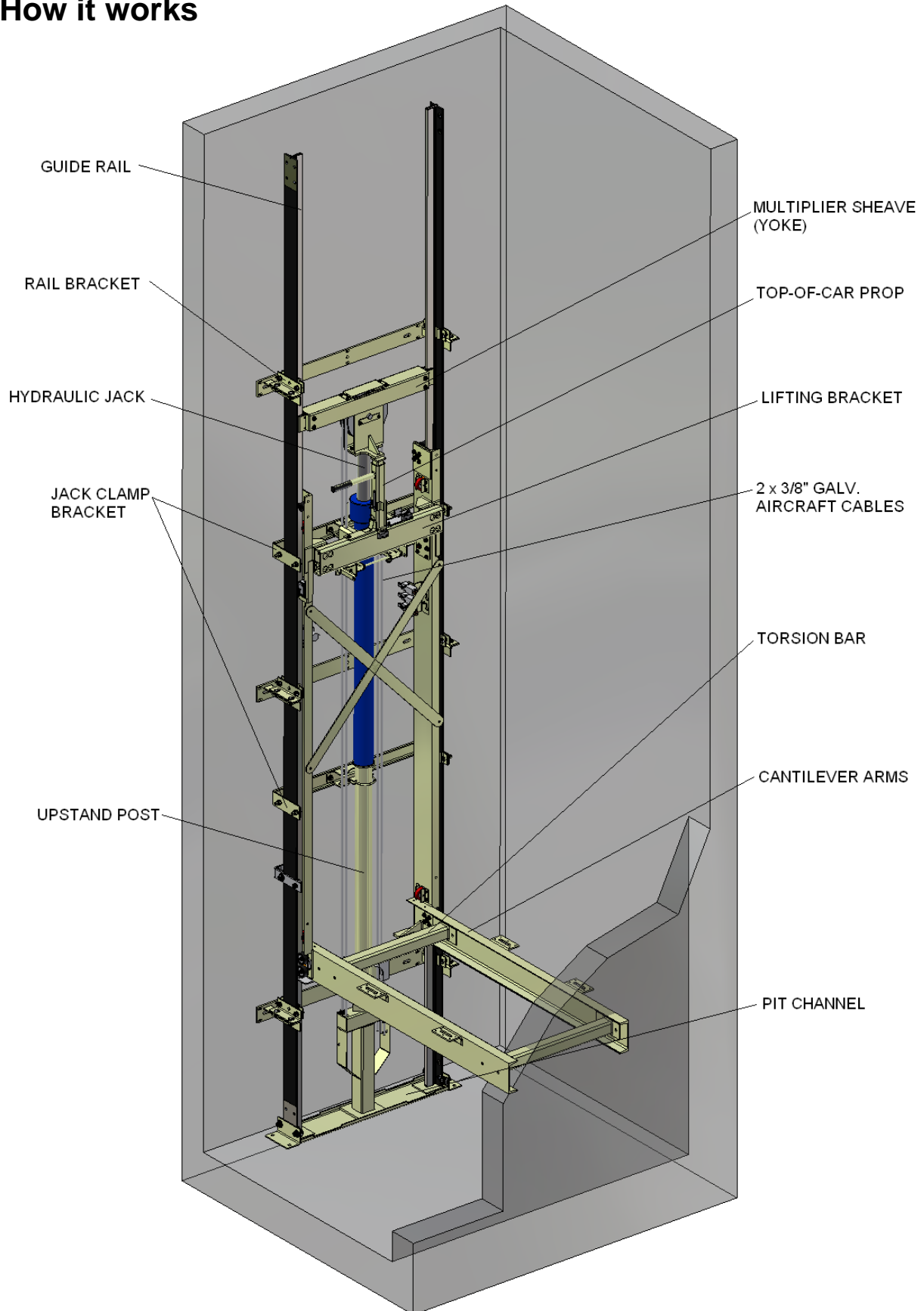

Hoistway

The walls of the elevator hoistway can be constructed of wood, poured concrete or concrete block. The wall behind the cylinder and guide rails must be load bearing and able to withstand the loads imposed by the lift.

The cylinder and guide rails are mounted to the wall with steel brackets. These rail brackets are fastened to the load bearing wall at regular intervals.

The rail bracket spacing is determined during the design phase. The rail brackets are generally every 4' apart, measured vertically, depending on the load capacity, size of cab and travel height. Please see final elevator shop drawings for actual locations.

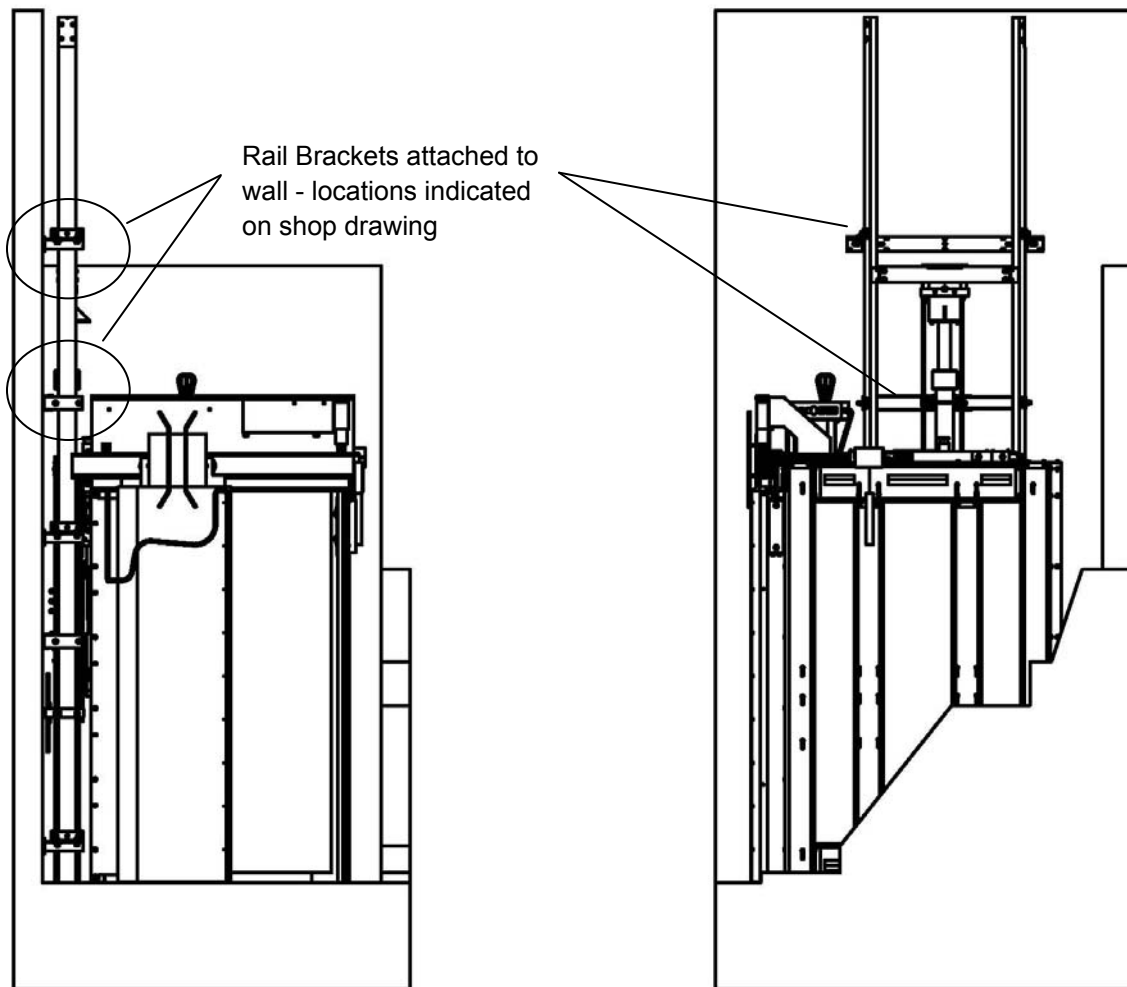

All the walls of the hoistway, especially the wall behind the rails and the entrance walls, need to be flush and plumb from floor to ceiling to within +/- 1/8". This is to allow for the required running clearances.

No light is required at the top of the hoistway as the car top is equipped with a standard caged light fixture for use by the mechanic during his maintenance visits. A light is required in the pit (see Construction of Pit for details).

Construction of Pit:

The pit must be the same width and length as the hoistway. The majority of the weight of the lift is borne by the plunger (ram). Reactions are indicated on each project's shop drawings. A 14" (355 mm) pit is recommended.

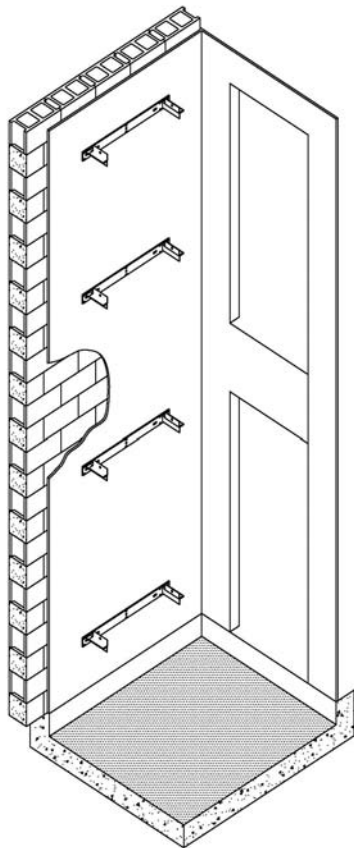
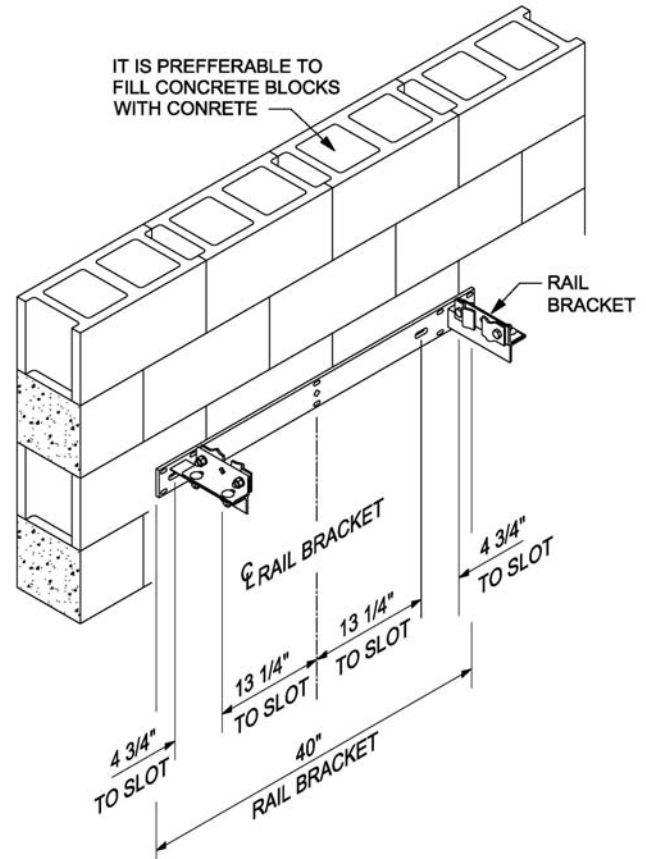

Overhead Clearance (Refuge Space) – 135" (3429mm)

is required above the upper landing level finished floor to the ceiling above to meet the refuge space required by code. On existing construction, a car top prop can be used to reduce the overhead to 118" (2997mm). If your overhead space is less than 118" (2997mm) please contact Garaventa as changes to the finished hoistway dimensions are required.

A **pit ladder** is required only if the pit depth exceeds 35" (900mm). Consult your Garaventa Lift representative for details as changes to finished hoistway are required.

Pit Lighting – A pit light and GFI duplex receptacle, supplied by the General Contractor, are required in the pit of your Elverson LU/LA for use by the mechanic during his maintenance visit. Consult Garaventa Lift for location and routing of conduit.

Habitable space below hoistway will require the pit to be increased in depth to a minimum 16" (406mm) to accommodate the required **buffer springs**.

Loading Diagram

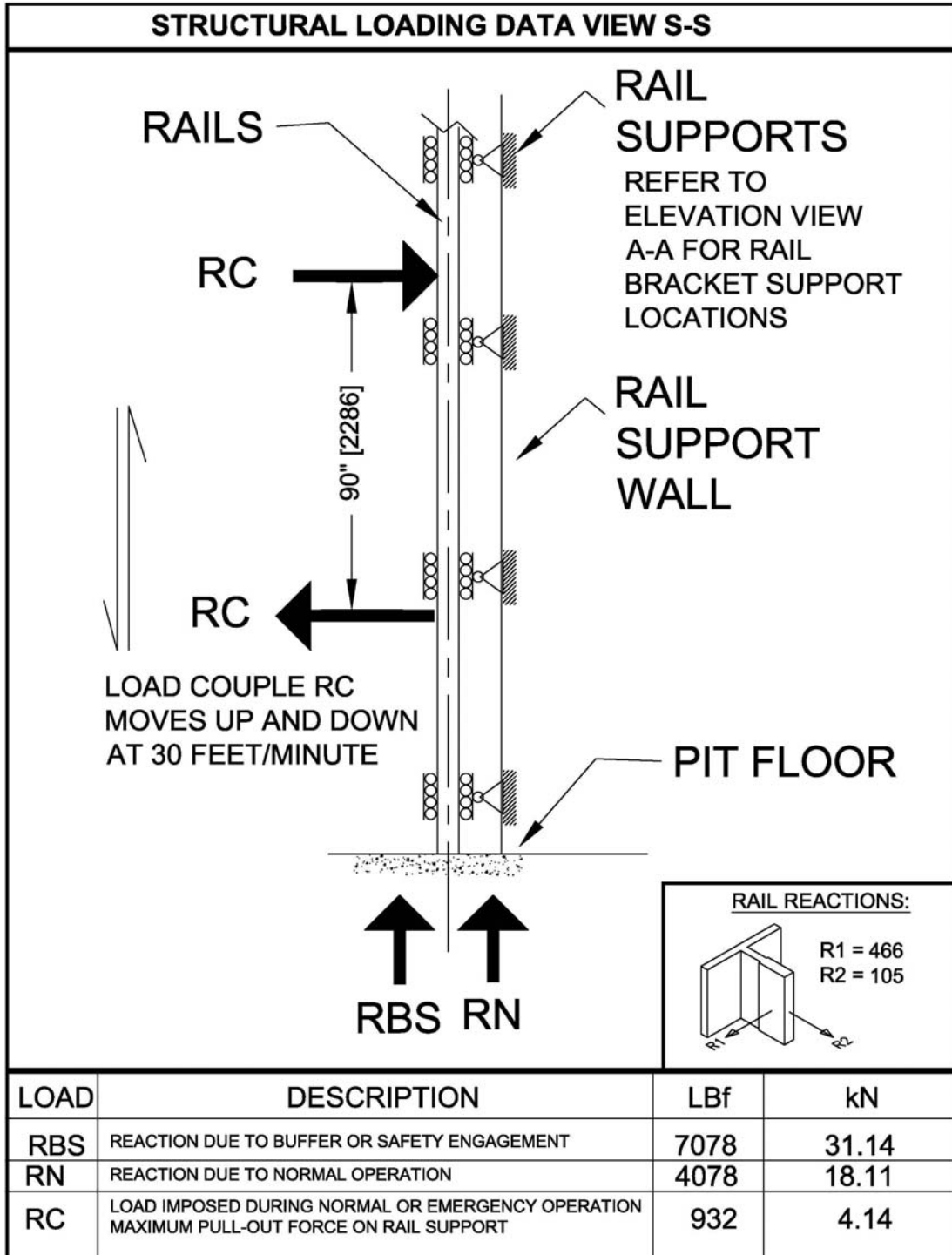

Car Sizes & Configurations

The Elvoron LU/LA is available in 5 different configurations to suit your building. Each configuration has specific car sizes. Custom car sizes are available - please contact Garaventa.

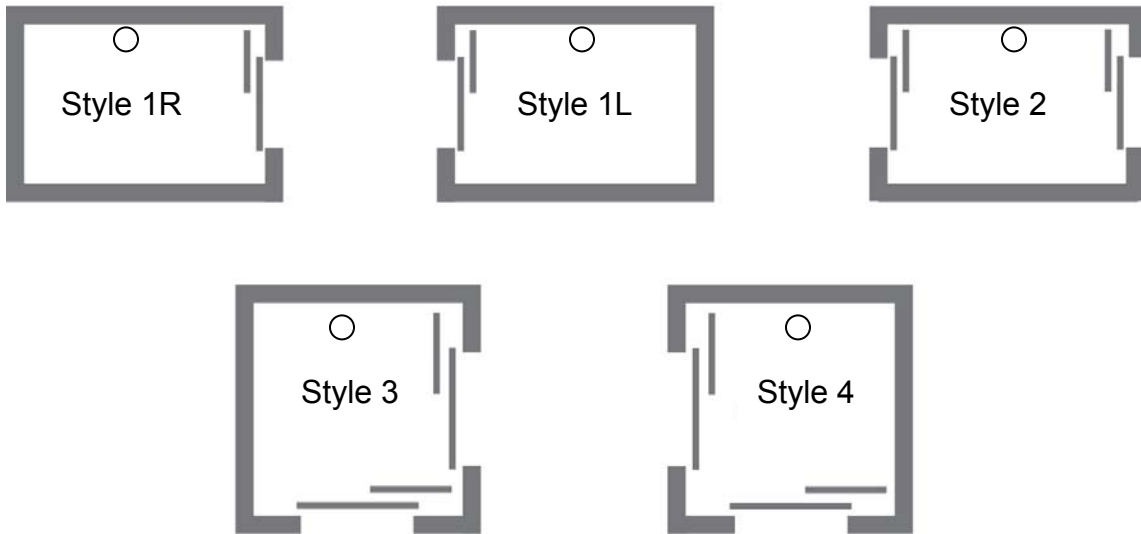

Style 1L & 1R Car sizes:

- 48" x 54" (1220 x 1372 mm)
- 42" x 60" (1067 x 1524 mm)

Style 2 Car sizes:

- 48" x 54" (1220 x 1372 mm)
- 42" x 60" (1067 x 1524 mm)

Style 3 & 4 Car sizes:

- 51" x 51" (1295 x 1295 mm)

Operating Controls

The controls of the Elvoron LU/LA are the same as would be found on a commercial elevator. Operation is fully automatic. The Car Operating Panel, Hall Stations and Direction Lantern are available in Brushed Stainless Steel, Brass and Antique Brass Finishes.

Car Operating Panel (COP)

The Elvoron LU/LA COP is equipped with a digital floor indicator, illuminated floor buttons, alarm button, door open and door close buttons and a keyed emergency stop switch. An optional **integrated hands free phone** is available.

Braille Markings for the COP, Hall Stations and Hall landings are included as standard equipment.



Hall Stations

The Hall Station buttons illuminate when pushed. The push button itself is always made of stainless steel for maximum durability. Wall plates are available in our three standard finishes. For increased safety and security, an optional key switch allows the entire elevator to be deactivated.

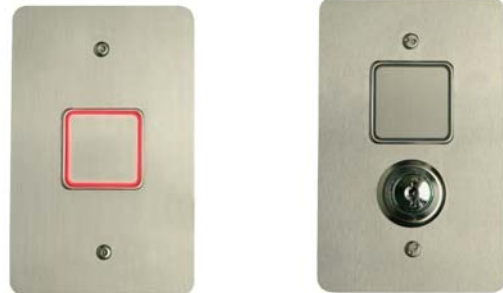

Car Direction Lantern

Mounted in the car to the car slam post opposite the COP, the Direction Lantern is an audio and visual signaling device that indicates direction of travel and arrival at the floor.



Car

Doors - Entrance and Car Doors

The Elvoron LU/LA uses commercial elevator entrance and car doors. When open the doors provide a **36" (915mm) x 80" (2032mm) clear opening**. They are two-speed horizontal doors and are equipped with full height photo-electric presence/obstruction sensors. The doors have an hour and a half fire rating.

The car doors are finished to match your car wall trim and the entrance doors are primed and ready to be painted to match your building décor. All doors can be supplied in brushed stainless steel.

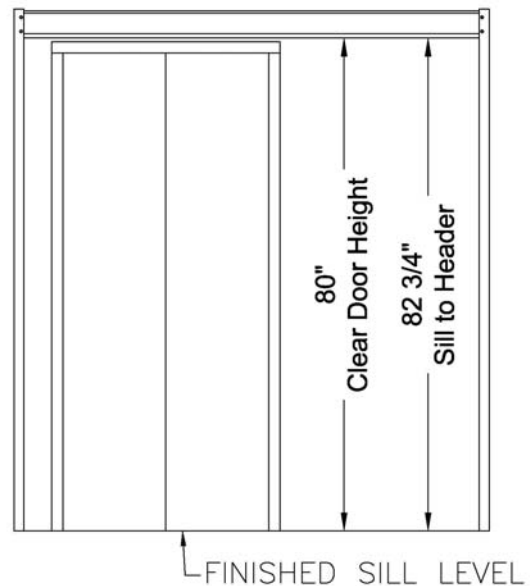

Corridor Elevation

Door Details – Masonry Walls

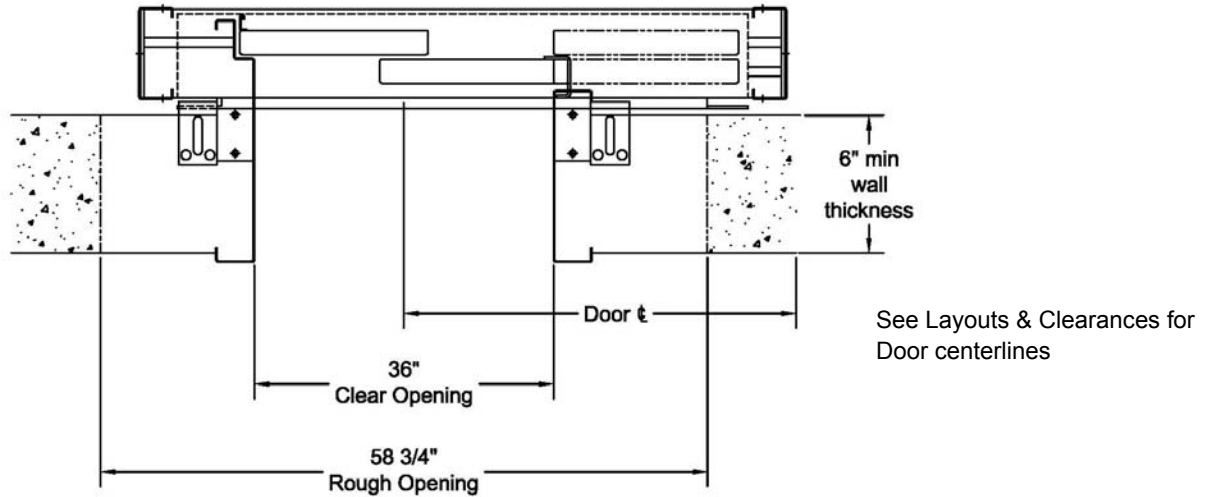

Plan View

Garaventa recommends that the walls on the entrance side of the hoistway be left open until the door frames are set. Or a rough opening can be left to accommodate for the doors to be placed. This allows the doors to be aligned with the centerline of the car.

Contact your local authorized Garaventa Lift representative for further details.

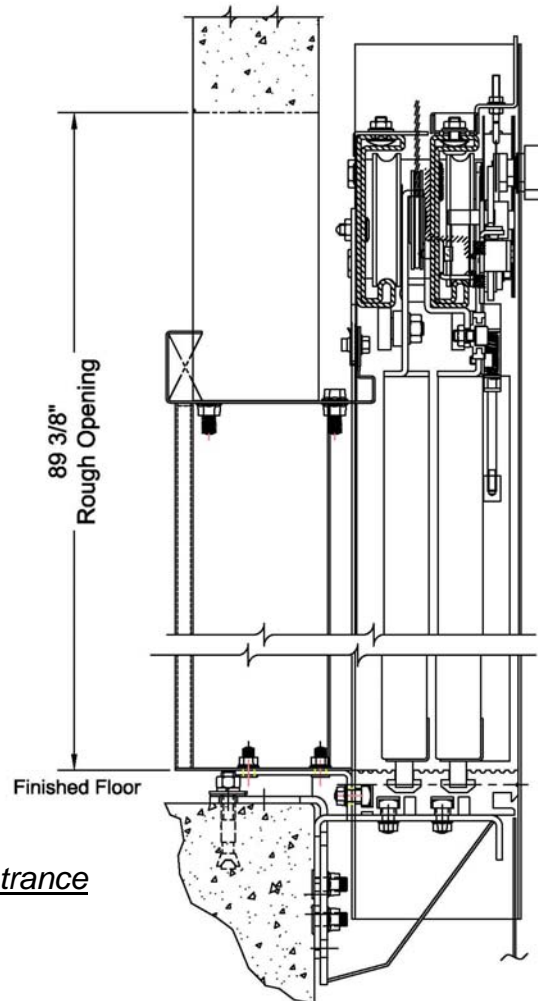

Section Through Entrance

Door Details – Wood and Drywall Walls

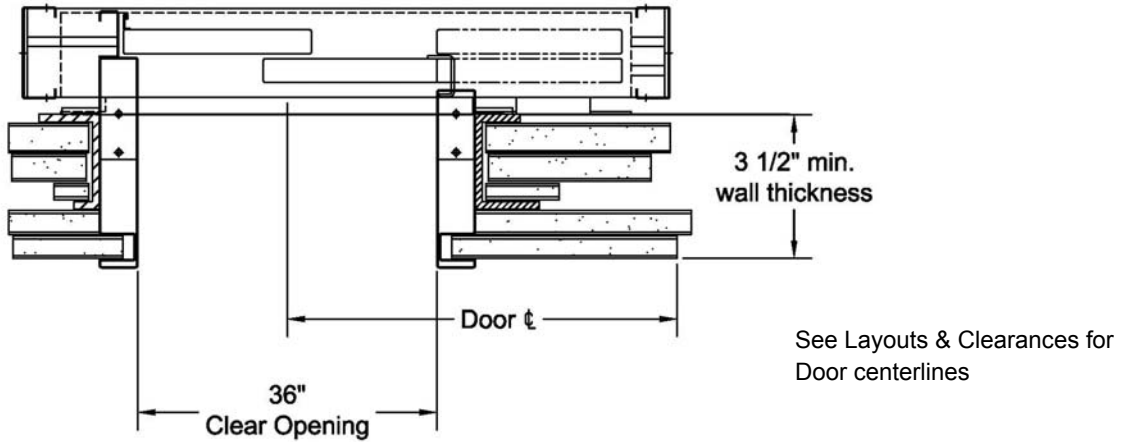

Plan View

Garaventa recommends that the walls on the entrance side of the hoistway be left open until the door frames are set. This allows the doors to be aligned with the centerline of the car.

Contact your local authorized Garaventa Lift representative for further details.

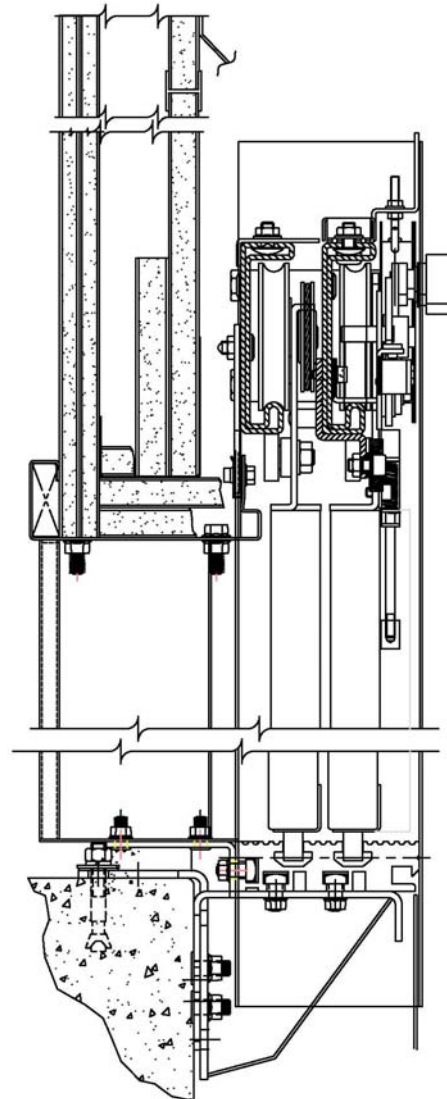

Section Through Entrance

51 x 51 Cab - Style 3

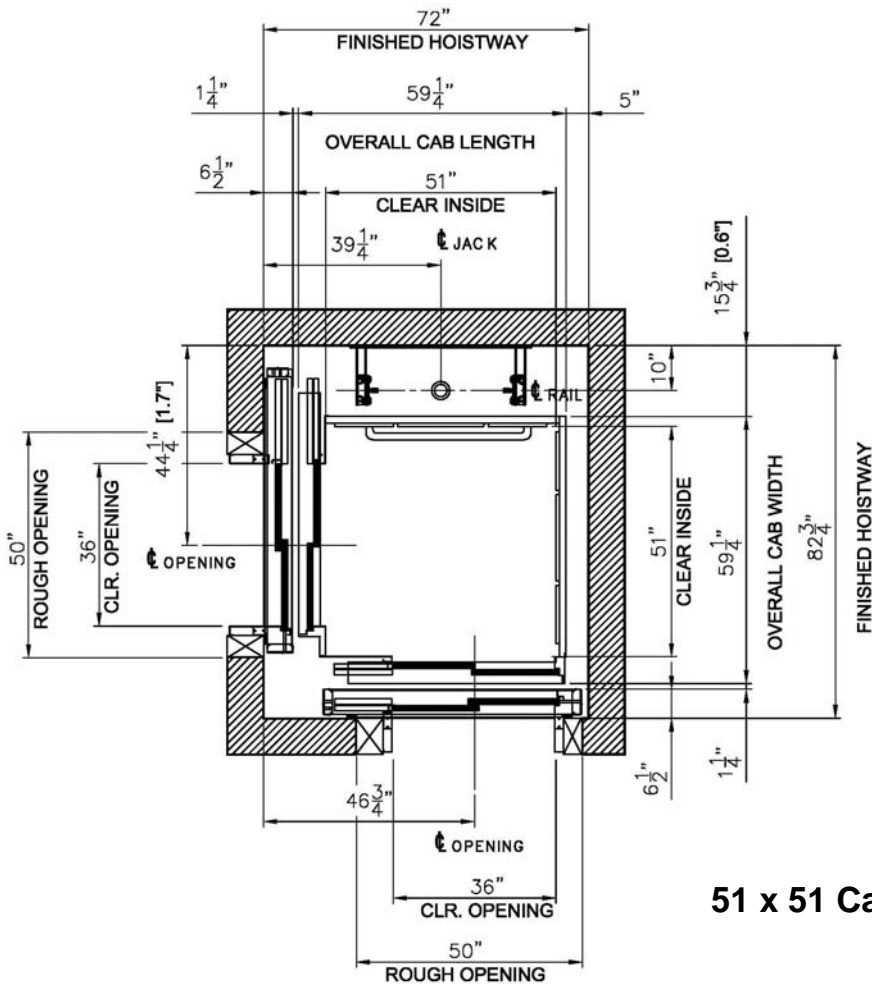
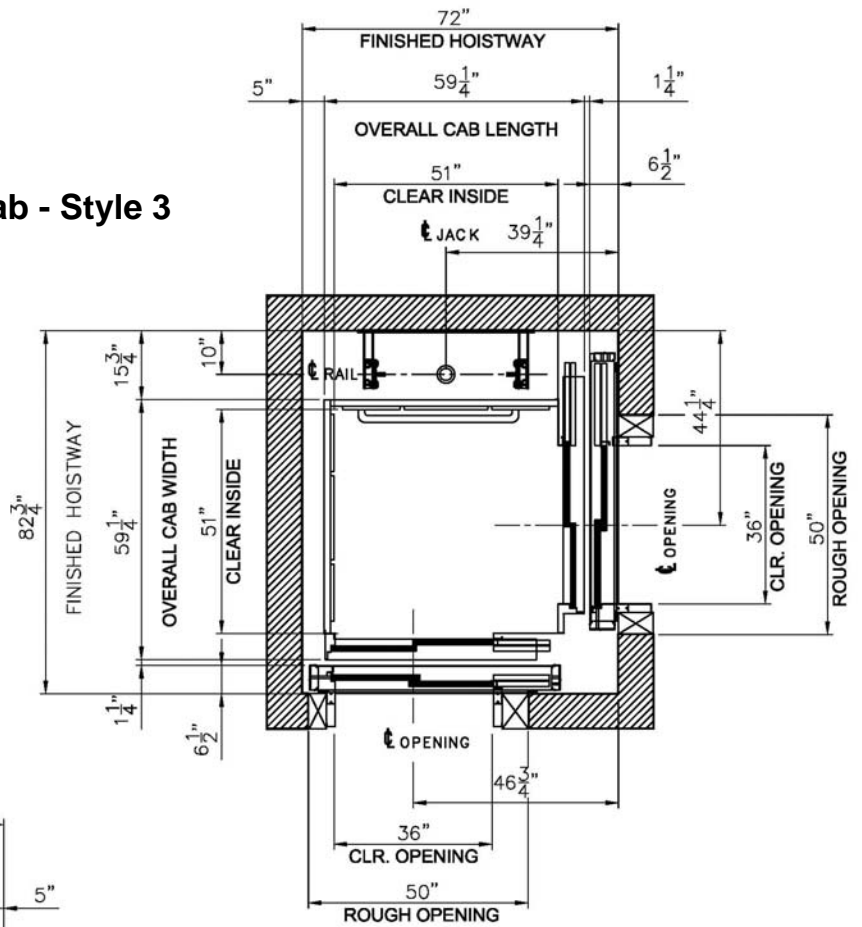

51 x 51 Cab - Style 4

Technical Information

Car Sizes:

48" x 54" (1220 x 1372mm)

42" x 60" (1067 x 1524mm)

51" x 51" (1295 1295mm)

Rated Load:

Standard: 1400 lbs (635 kg)

Speed:

Standard: 30 fpm (0.15 m/s) nominal speed

Option: 40 fpm (0.2 m/s) – *contact Garaventa*

Travel Range:

Standard: 25 ft (7.6 meters)

Option: 30 ft (9.1 meters) – *contact Garaventa*

Stops:

Up to 6 stops

Pit Depth:

Recommended pit depth of 14" (355 mm),
Pit Prop standard equipment with elevator.

Overhead Clearance (Refuge Space):

135" (3429mm) min. standard overhead

118" (2997mm) min. overhead in existing
construction with the use of a car top prop

– *contact Garaventa*

Less than 118" (2997mm) – *contact Garaventa*

Drive System:

1:2 Cable Hydraulic, Heavy Duty car sling
with roller guide shoes running on 8 lb. per
foot steel T-rails, Quiet submersed pump
and motor (5 HP), Factory pre-set and tested 2-speed valve for smooth start and stop

Power Supply:

Elevator: Standard: 208 VAC three phase

Option: 230 VAC single phase

Lighting: 110 VAC single phase, 15 amps

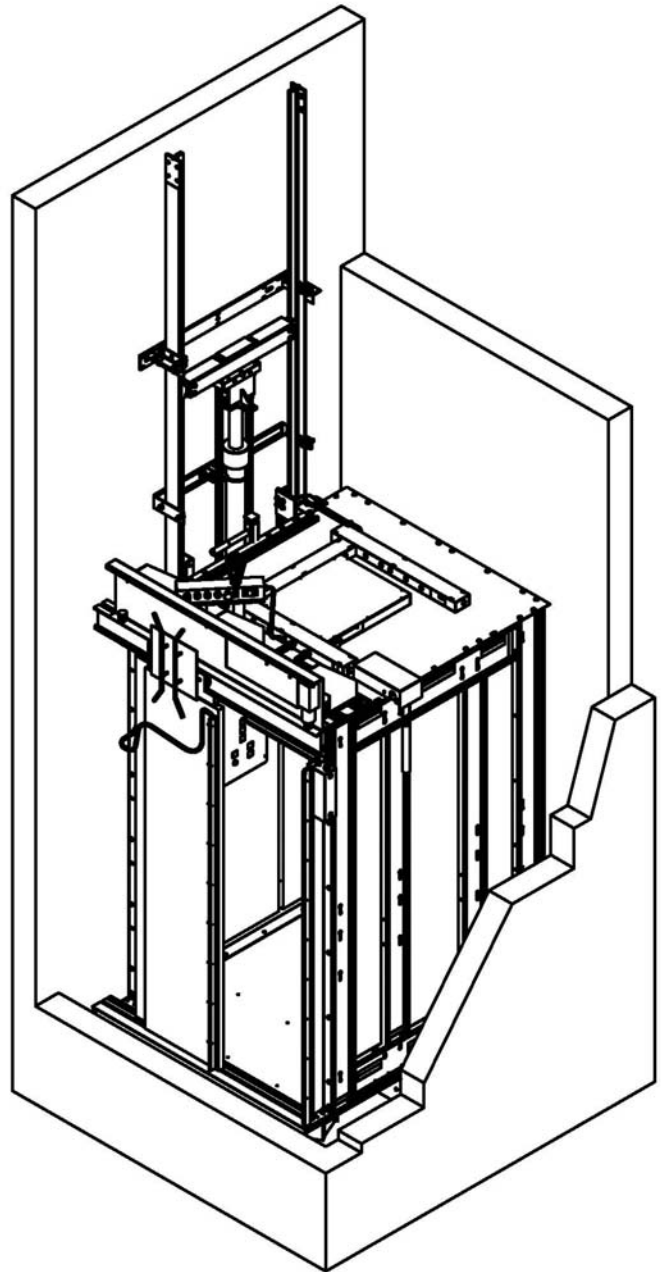

Controls:

Fully automatic push button operation, PLC Controller, integrated self-diagnostics. digital floor indicator in car, automatic car lighting upon entry, Illuminated push buttons, car Arrival lanterns in car door jamb

Doors:

36" x 80" (914 x 2032mm) two-speed horizontal sliding hoistway and car doors with 1.5 hour fire rating

Safety Features:

Uninterruptible Power Supply (UPS) emergency backup power system, emergency manual lowering valve, safety brake system, 2 speed door operators with integral gate switch, automatic bi-directional floor leveling, emergency alarm button in car, emergency keyed stop switch in car, overspeed valve, final limit switch and low oil protection timer circuit

Unique Standard Features:

Braille markings, car direction lantern comes with audio and visual signals, full height photo-electric presence/obstruction sensors, automatic home park feature

Code Compliance:

ASME A17.1, Section 5.2 LU/LA Elevators

CSA B-44, Section 5.2 LU/LA Elevators

ADA (Americans with Disabilities Act)

Popular Options:

Integrated hands free telephone, custom car finishes, additional handrails, Fireman service (Phase 1), car top prop, buffer springs (increases your pit depth), keyed hoistway access

Machine Room Requirements

In order to meet the code requirements, the hydraulic pump unit, GFI duplex receptacle and fused disconnect switches (elevator lighting) must be located in a dedicated machine room with a minimum overhead of 7' (2134 mm). Adequate working space in the machine room includes, clearance in front of the pump unit and the proper location of the light switch and disconnect switches. Please refer to your job specific shop drawings or contact your local authorized Garaventa Lift representative for further details..

The optimum location is at the lowest level of the building, adjacent to the hoistway, preferably on the same side as the guide rails. The dimensions of the pump unit are 30" wide x 19 1/2" deep x 66 1/4" high (762 x 495 x 1683 mm). It can be remotely located, up to 10' (3048 mm) away from the hydraulic jack.

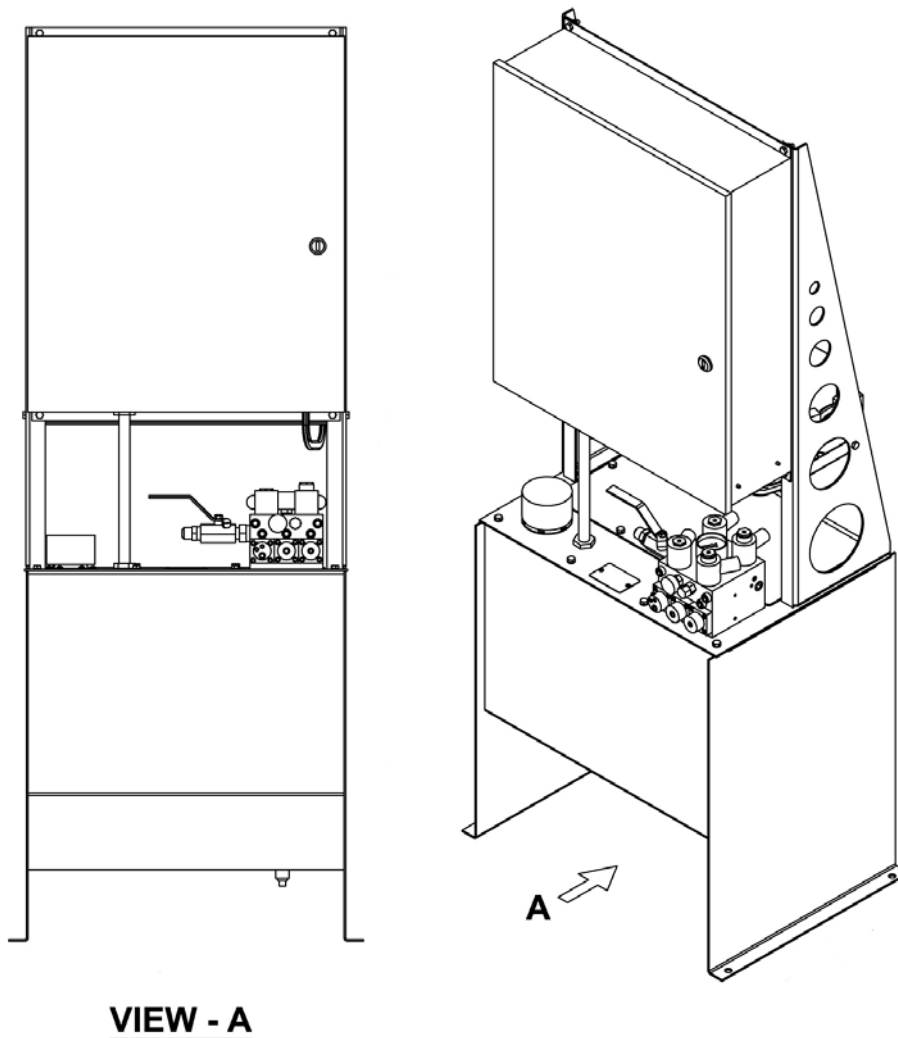

Please contact your Local Garaventa representative for specific Machine room Code Requirements.

Machine Room Layouts

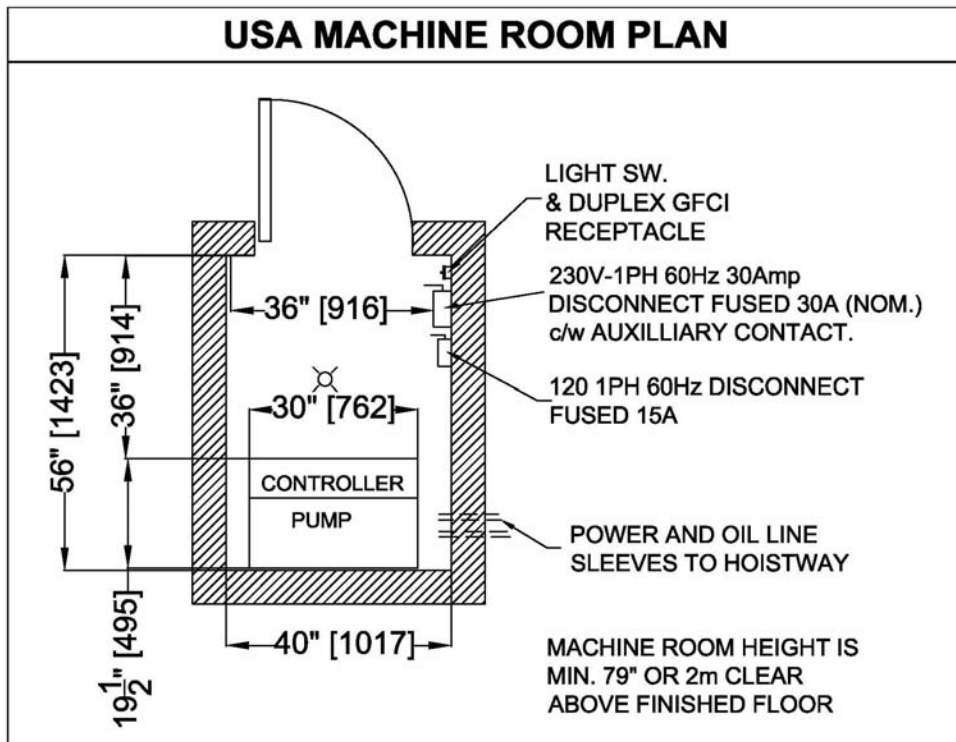
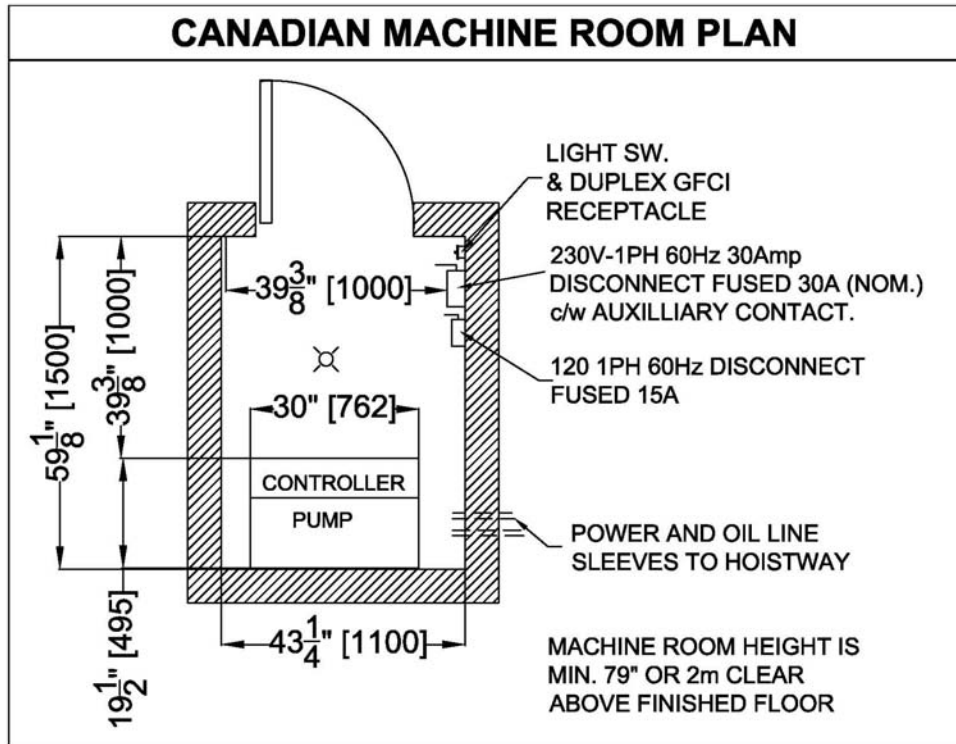

Please contact your Local Garaventa representative for specific Machine room Code Requirements.

Two dedicated PVC sleeves, at least 3" (76 mm) in diameter, will be required between the hoistway and the machine room, one sleeve for the hydraulic hose and one for the electrical conduit. This is to enable the installers to make the connection between the cylinder and the pumping unit. The sleeves should enter the hoistway at either corner of the support wall.

Contact your local authorized Garaventa Lift representative for code specific requirements and further details.

Lighting – The machine room must be provided with at least 100 lx lighting over the pumping unit and disconnect switches.

Electrical Disconnects – In the machine room you will need to provide two lockable fused disconnects – one 15 amp for lighting and one 30 amp for the pumping unit. Disconnect switches should be located on the strike (lock) side of the machine room door. In accordance to the electrical code, you must provide a minimum of 39 $\frac{3}{8}$ " (1000 mm) of working space in front of each disconnect switch.

The 30A disconnect switch for the pump unit requires an auxiliary contact.

The fused disconnect switch rating and fuse rating for the lift will be shown on the shop drawings for your project.

At least one GFCI duplex receptacle connected to a 15 amp branch circuit shall be installed in the machine room.

Ventilation Requirements – No special requirements, the elevator pump unit will generate approximately 3200 BTU per hour under normal operating conditions.

Mains Power Requirements – The standard motor on the pump unit is 5 HP and it can be ordered to suit either three phase or single phase power.

Standard – 208 VAC Three phase 20 amps

Optional – 230 VAC Single phase 30 amps

