



**WAUPACA**  
**ELEVATOR** COMPANY, INC.  
Specify the Specialists®

# Planning Guide

**Cable-Waiter™**  
**Paca-Waiter®**  
**Dumbwaiters**



We are a proud member of the Accessibility Equipment Manufacturers Association. This symbol assures you of our commitment to high quality and accessibility to everyone.



## Waupaca Elevator Mission Statement

Our company’s mission is to supply and service products that meet or exceed our customers’ expectations of high quality, value, delivery and longevity. Our success is a direct reflection of our employees’ involvement and commitment to excellence. We strive to continuously improve our products to ensure meeting the future requirements of our customers and facilitate competitive growth.



## CSI 3-Part Specifications

Customize and download CSI 3-Part Specifications by logging on to:

[www.arcat.com](http://www.arcat.com) - specify Waupaca Elevator as the requested manufacturer

[www.waupacaelevator.com](http://www.waupacaelevator.com) - go to “Architect Section” click on linking icon

## Table of Contents

|   |      |
|---|------|
| Introduction .....                          | 4    |
| Quick Guide to Dumbwaiters & Features ..... | 5    |
| Dumbwaiter Hoistway Illustration .....      | 6    |
| Dumbwaiter Series Information .....         | 7    |
| Hoistway Layout .....                       | 8-12 |
| Electrical Room .....                       | 13   |
| Dumbwaiter Equipment .....                  | 14   |
| Dumbwaiter Series Examples .....            | 15   |
| Elevation Layout for Bi-Part Doors .....    | 16   |



---

# Introduction

This Planning Reference Guide is to be used as a guide in deciding the type of dumbwaiter to be installed, parameters of installation and steps taken to achieve a proper dumbwaiter installation. This guide may be used by the architect, contractor, dealer or home owner. The information in this guide is intended as an overview, each installation will have job specific specifications that must be followed. Do not attempt to construct a hoistway on this information alone.

Dumbwaiter installation is to be done by an authorized elevator contractor, and in accordance with installation instructions provided by the manufacturer. Installation must also be in compliance with requirements of the National Electric Code, American Society of Mechanical Engineers safety code, and state and local building codes. Waupaca Elevator's products are designed to meet the requirements of ASME - 17.1 National Elevator Codes for dumbwaiters and are fully certified by a registered professional engineer. Waupaca Elevator Company, Inc. dumbwaiters manufactured and installed under the proper parameters are warranted for 2 years. Manufacturer assumes no liability for equipment not installed in compliance with these codes.

---

# Planning Steps

1. - Locate local dealer and together determine the following:
  - A - Select weight capacity, car type and design specifications
  - B - Address national, state and local code requirements
  - C - Hoistway size
  - D - Car size, layout and options
  - E - Machine location
  - F - Electrical requirements
2. - Obtain and follow site specific field drawings while building hoistway, doorways and any other construction related to the dumbwaiter.
3. - Coordinate with dealer to install dumbwaiter.



## Dumbwaiter Quick Reference Guide

| Mechanical Features | Cable-Waiter                    |             | Paca-Waiter                  |              |               |
|---------------------|---------------------------------|-------------|------------------------------|--------------|---------------|
|                     | 50 lbs.                         | 100 lbs.    | 200 lbs.                     | 300 lbs.     | 500 lbs.      |
| Weight Capacity     | 50 lbs.                         | 100 lbs.    | 200 lbs.                     | 300 lbs.     | 500 lbs.      |
| Standard Car Size   | 16"x16"x24"                     | 20"x20"x30" | 26"x26"x36"                  | 30"x30"x40"  | 36"x36"x48"   |
| Motor               | 3/4 HP                          | 3/4 HP      | 1 HP                         | 2 HP         | 2 HP          |
| Phase               | Single                          | Single      | Single/Three                 | Single/Three | Single/Three  |
| Volts               | 110                             | 110         | 208, 230                     | 208, 230     | 208, 230      |
| Amps                | 20                              | 20          | 20/30                        | 20/30        | 20/30         |
| Controller Size     | 18"x18"x6"                      | 18"x18"x6"  | 18"x18"x6"                   | 18"x18"x6"   | 18"x18"x6"    |
| Sheave Diameter     | 4"                              | 4"          | 6-3/8"                       | 6-3/8"       | 7-1/2"        |
| Drum Diameter       | 5-1/4"                          | 5-1/4"      | 5-3/4"                       | 5-3/4"       | 6-3/4"        |
| Rails               | 1-1/2 x 1-1/2 x 1/8 Angle Steel |             | 2 x 1 x 3/16 C-Channel Steel |              |               |
| Cables              | 1/8 x 7 x 19                    |             | 3/16 x 7 x 19                |              | 7/32 x 7 x 19 |

| Optional Features    | Description  |
|----------------------|--|
| Machine Placement    | Rail Mounted: Above Car, Below Car   |
| Car                  | Primed Steel, Stainless Steel, Wood  |
| Car Opening          | Single, Opposite, Adjacent   |
| Access Door          | Primed Steel, Stainless Steel  |
| Gates                | Bi-Part - Slide Up (primed steel or stainless), Roll Top (wood on roll top only) |
| Hall Station Options | Call & Send, Car Here, In Use Light, Lantern & Gong                              |
| Safety Locks         | Single Contact Interlock: GAL, EMI, HGI (provided with hoistway door)            |
|                      |  |

# Electrical Room - Dumbwaiters

## Typical Electrical Layout

1. The controller requires a clear space of 36" X 30" directly in front of it (refer to example above).
2. A lockable service disconnect must be placed within sight of the controller and easily accessible from the latch side of the doorway.
3. The temperature should be maintainable between 60° F - 110° F and should not be exposed to the elements.

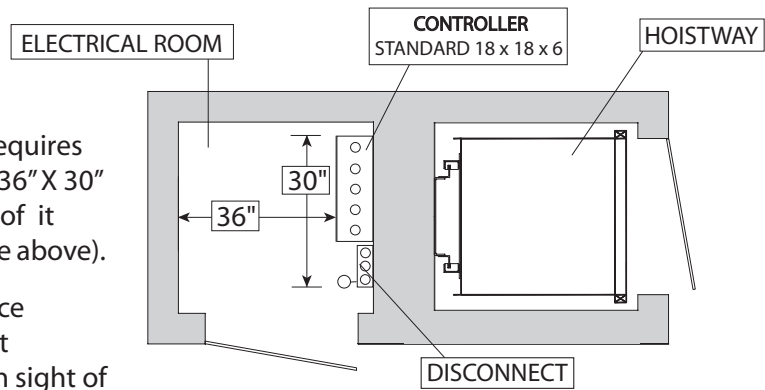

## Hoistway Illustrations - Dumbwaiters

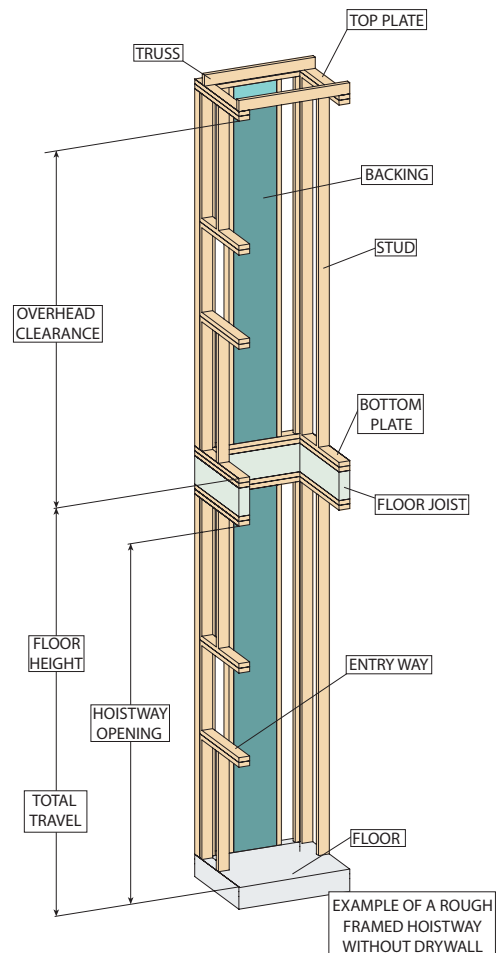

# Hoistway Construction

The typical layouts shown here may vary from your actual hoistway. The purpose of these layouts are for a general understanding. Please refer to the Waupaca Elevator drawings and specifications that will be provided by the company.

These drawings depict sample construction only. It is the responsibility of the installer/ contractor or engineer to design and specify structural supports. All construction to be in compliance with local codes.

## Cable-Waiter Series 007

### HORIZONTAL PULLOUT FORCES

|              |     |         |
|--------------|-----|---------|
| Cable-Waiter | 50  | 27 lbs. |
| Cable-Waiter | 100 | 56 lbs. |

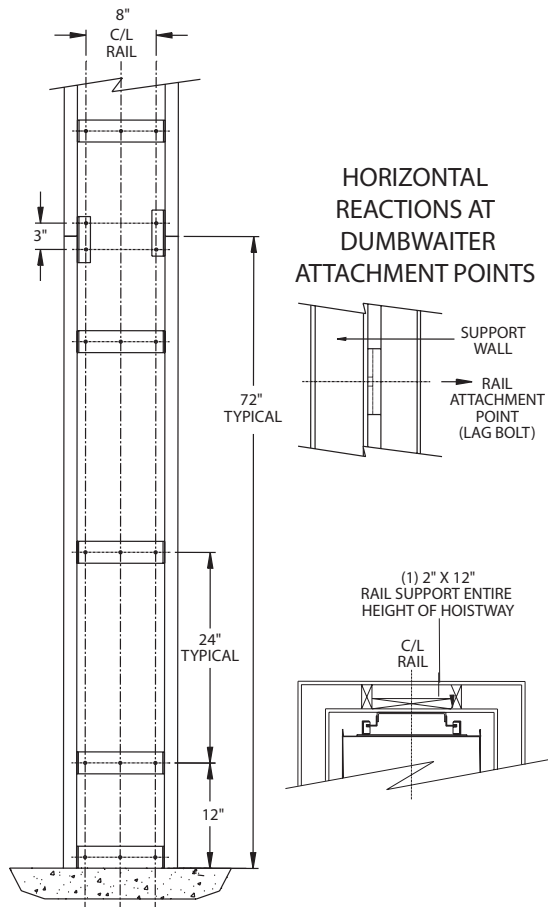

## Paca-Waiter Series 011

### HORIZONTAL PULLOUT FORCES

|             |     |          |
|-------------|-----|----------|
| Paca-Waiter | 200 | 124 lbs. |
| Paca-Waiter | 300 | 196 lbs. |
| Paca-Waiter | 500 | 334 lbs. |

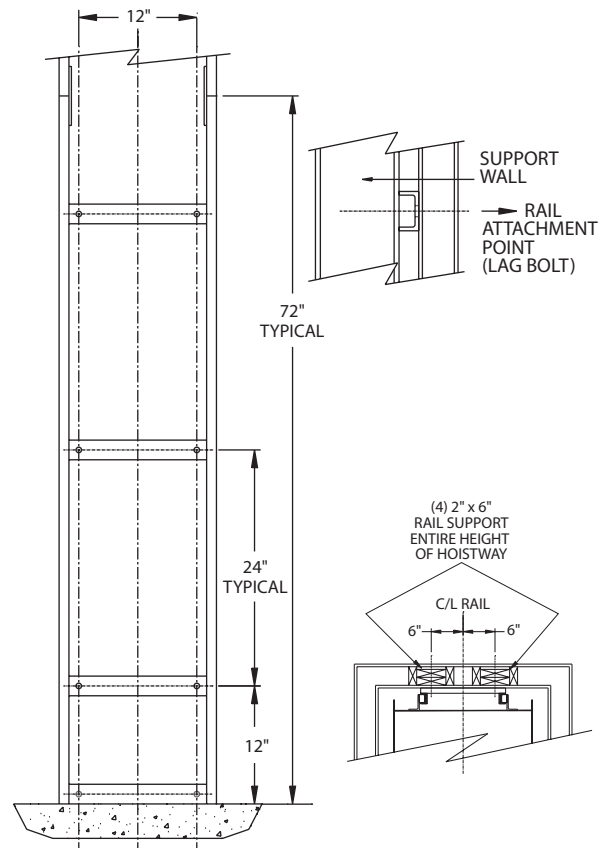

# Car Gate

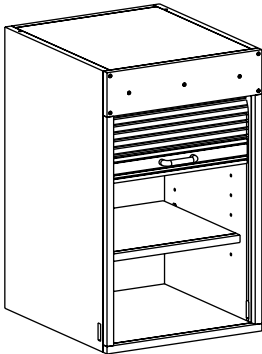
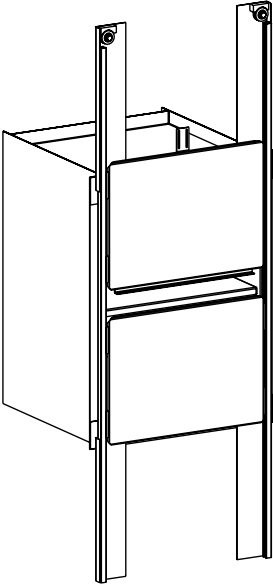
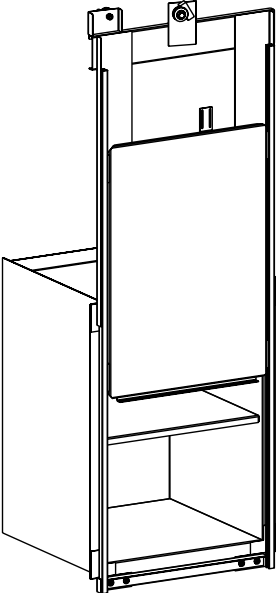

The dumbwaiter car gate, is attached to the front of the car and travels with it up and down the hoistway. The gate prevents items from leaving or entering the car.

|  |   |   |
|--|---|---|
|                    |                              |                             |
| <p><b>Wooden Car &amp; Wood Rolltop Gate</b></p>   | <p><b>Steel Car with Bi-Parting Gate</b></p>  | <p><b>Steel Car with Slide-Up Gate</b></p>  |
| <p><b>Cable-Waiter</b><br/>50 lbs. &amp; 100 lbs.</p> <p>Wooden car with<br/>Wooden Rolltop Gate</p> | <p><b>Cable-Waiter</b><br/>50 lbs. &amp; 100 lbs.</p> <p>Painted Steel<br/>or<br/>Stainless Steel</p>           | <p><b>Cable-Waiter</b></p> <p>This option<br/>is not<br/>available</p>  |
| <p><b>Paca-Waiter</b><br/>200 lbs.</p> <p>Wooden car with<br/>Wooden Tambor Gate</p>                 | <p><b>Paca-Waiter</b><br/>200 lbs., 300 lbs. &amp; 500 lbs.</p> <p>Painted Steel<br/>or<br/>Stainless Steel</p> | <p><b>Paca-Waiter</b><br/>200 lbs., 300 lbs. &amp; 500 lbs.</p> <p>Painted Steel<br/>or<br/>Stainless Steel</p> |

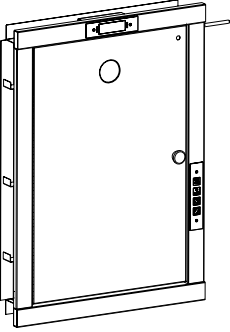

# Hoistway Door - Dumbwaiters

The door prevents items from accidentally entering the hoistway when the dumbwaiter car is elsewhere. An interlock located at each opening prevents the door from being opened if the dumbwaiter car is not waiting at that landing. We offer the following doors, or the door can be made to our specification by a third party, either way, every opening must have a door.

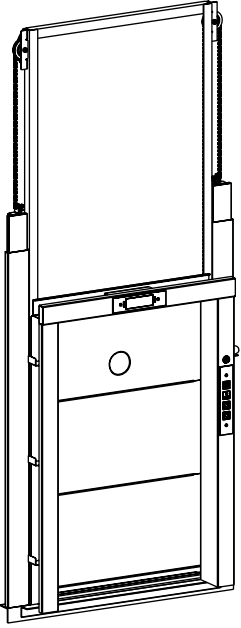
| <b>CONSTRUCTION/INSTALLATION NOTE!</b><br><b>Hoistway door walls must not be erected until doors are set in place.</b> |   |   |
|--|---|---|
|  <p>Maximum Height of 36"</p>        |      |     |
| <b>Swing Door</b>  | <b>Bi-Parting Door</b>  | <b>Slide-Up Door</b>  |
| <b>Cable-Waiter</b><br>50 lbs. & 100 lbs.<br>Painted Steel or Stainless Steel  | <b>Cable-Waiter</b><br>50 lbs. & 100 lbs.<br>Painted Steel or Stainless Steel           | <b>Cable-Waiter</b><br>This option is not available                                     |
| <b>Paca-Waiter</b><br>200 lbs., 300 lbs. & 500 lbs.<br>Painted Steel or Stainless Steel                                | <b>Paca-Waiter</b><br>200 lbs., 300 lbs. & 500 lbs.<br>Painted Steel or Stainless Steel | <b>Paca-Waiter</b><br>200 lbs., 300 lbs. & 500 lbs.<br>Painted Steel or Stainless Steel |



## Construction Notes

### - Paca-Waiter® and Cable Waiter™

|                   |          |            |          |
|-------------------|----------|------------|----------|
| Series <b>007</b> | 50 lbs.  | <b>011</b> | 200 lbs. |
|                   | 100 lbs. |            | 300 lbs. |
|                   |          |            | 500 lbs. |

- Use specified backing from architect to frame into wall.
- The following hoistway illustrations are showing finished dimensions. Finished hoistway dimensions include drywall installation, plaster and paint.
- Rough frame door in place with an extra inch of space on all sides of the door to later install the door and door trim.
- Do not complete door and associated framing to one door (preferably at grade level), until dumbwaiter installation is complete.

## Car Opening Configurations and Coding

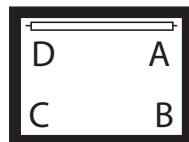
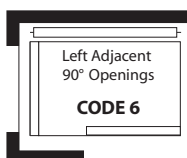
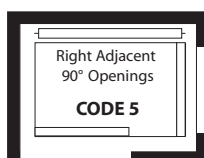
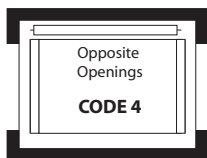
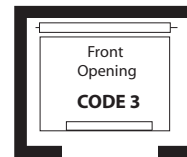
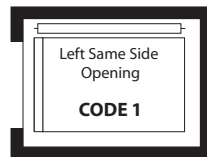

- 1- The D A is the side on which the rail is mounted.
- 2- The first letter refers to the attachment location of the gate.
- 3- The second letter refers to the location of the strike plate.
- 4- If present, the third letter "R" denotes a recessed gate.

**Opposite Openings  
ABR DCR**

|                         |                     |
|-------------------------|---------------------|
| <b>Example: ABR DCR</b> |                     |
| First Gate - ABR        | Second Gate - DCR   |
| A- gate attachment      | D - gate attachment |
| B - strike plate        | C - strike plate    |
| R - recessed gate       | R - recessed gate   |

# Hoistway Layout - Dumbwaiter

The dumbwaiters listed in the following section are based upon our standard car. Cars can be customized to meet your unique needs.

## Wood Car with Classic Roll Top Gates

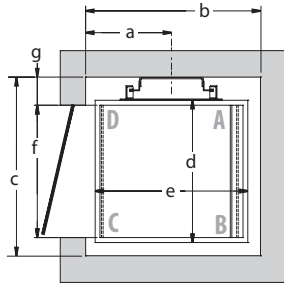

### LEFT OPENINGS (DC) Code 1

| Dumbwaiter Type       | GATED WOOD DUMBWAITER |                              |        |        |       |     |     |       |
|-----------------------|-----------------------|------------------------------|--------|--------|-------|-----|-----|-------|
|                       | Car Size              | Finished Hoistway Dimensions |        |        |       |     |     |       |
| Left Opening          |                       | a                            | b      | c      | d     | e   | f   | g     |
| Cable-Waiter 50 lbs.  | 16"x16"x24"           | 11.25"                       | 23.25" | 23"    | 17.5" | 20" | 16" | 4.25" |
| Cable-Waiter 100 lbs. | 20"x20"x30"           | 13.25"                       | 27.25" | 27"    | 21.5" | 24" | 20" | 4.25" |
| Paca-Waiter 200 lbs.  | 26"x26"x36"           | 16.25"                       | 33.25" | 33.75" | 27.5" | 30" | 26" | 5"    |

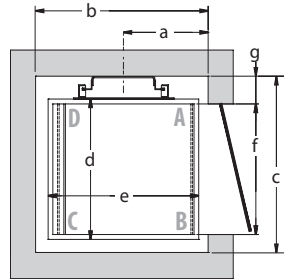

### RIGHT OPENINGS (AB) Code 2

| Dumbwaiter Type       | GATED WOOD DUMBWAITER |                              |        |        |       |     |     |       |
|-----------------------|-----------------------|------------------------------|--------|--------|-------|-----|-----|-------|
|                       | Car Size              | Finished Hoistway Dimensions |        |        |       |     |     |       |
| Right Opening         |                       | a                            | b      | c      | d     | e   | f   | g     |
| Cable-Waiter 50 lbs.  | 16"x16"x24"           | 11.25"                       | 23.25" | 23"    | 17.5" | 20" | 16" | 4.25" |
| Cable-Waiter 100 lbs. | 20"x20"x30"           | 13.25"                       | 27.25" | 27"    | 21.5" | 24" | 20" | 4.25" |
| Paca-Waiter 200 lbs.  | 26"x26"x36"           | 16.25"                       | 33.25" | 33.75" | 27.5" | 30" | 26" | 5"    |

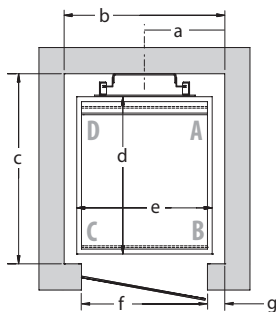

### FRONT OPENINGS (CB) Code 3

| Dumbwaiter Type       | GATED WOOD DUMBWAITER |                              |        |        |     |       |     |    |
|-----------------------|-----------------------|------------------------------|--------|--------|-----|-------|-----|----|
|                       | Car Size              | Finished Hoistway Dimensions |        |        |     |       |     |    |
| Front Opening         |                       | a                            | b      | c      | d   | e     | f   | g  |
| Cable-Waiter 50 lbs.  | 16"x16"x24"           | 10.75"                       | 21.75" | 24.75" | 20" | 17.5" | 16" | 2" |
| Cable-Waiter 100 lbs. | 20"x20"x30"           | 12.75"                       | 25.5"  | 28.75" | 24" | 21.5" | 20" | 2" |
| Paca-Waiter 200 lbs.  | 26"x26"x36"           | 15.75"                       | 31.5"  | 35.50" | 30" | 27.5" | 26" | 2" |



# Hoistway Layout - Dumbwaiters

The dumbwaiters listed in the following section are based upon our standard car. Cars can be customized to meet your unique needs.

## Steel Car with Gates

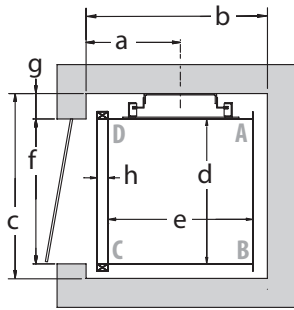

### LEFT OPENING (DC) Code 1

| Dumbwaiter Type       | GATED DUMBWAITER |                              |        |        |     |     |     |       |      |
|-----------------------|------------------|------------------------------|--------|--------|-----|-----|-----|-------|------|
|                       | Car Size         | Finished Hoistway Dimensions |        |        |     |     |     |       |      |
| LEFT OPENING          |                  | a                            | b      | c      | d   | e   | f   | g     | h    |
| Cable-Waiter 50 lbs.  | 16"x16"x24"      | 10.75"                       | 21.75" | 21.5"  | 16" | 16" | 16" | 3.5"  | 1.5" |
| Cable-Waiter 100 lbs. | 20"x20"x30"      | 12.75"                       | 24.75" | 25.5"  | 20" | 20" | 20" | 3.5"  | 1.5" |
| Paca-Waiter 200 lbs.  | 26"x26"x36"      | 15.75"                       | 30.75" | 33.25" | 26" | 26" | 26" | 4.25" | 1.5" |
| Paca-Waiter 300 lbs.  | 30"x30"x40"      | 17.75"                       | 34.75" | 37.25" | 30" | 30" | 30" | 4.25" | 1.5" |
| Paca-Waiter 500 lbs.  | 36"x36"x48"      | 20.75"                       | 40.75" | 43.25" | 36" | 36" | 36" | 4.25" | 1.5" |

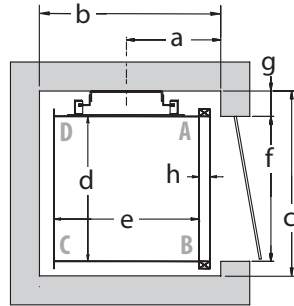

### RIGHT OPENING (AB) Code 2

| Dumbwaiter Type       | GATED DUMBWAITER |                              |        |        |     |     |     |       |      |
|-----------------------|------------------|------------------------------|--------|--------|-----|-----|-----|-------|------|
|                       | Car Size         | Finished Hoistway Dimensions |        |        |     |     |     |       |      |
| RIGHT OPENING         |                  | a                            | b      | c      | d   | e   | f   | g     | h    |
| Cable-Waiter 50 lbs.  | 16"x16"x24"      | 10.75"                       | 21.75" | 21.5"  | 16" | 16" | 16" | 3.5"  | 1.5" |
| Cable-Waiter 100 lbs. | 20"x20"x30"      | 12.75"                       | 24.75" | 25.5"  | 20" | 20" | 20" | 3.5"  | 1.5" |
| Paca-Waiter 200 lbs.  | 26"x26"x36"      | 15.75"                       | 30.75" | 33.25" | 26" | 26" | 26" | 4.25" | 1.5" |
| Paca-Waiter 300 lbs.  | 30"x30"x40"      | 17.75"                       | 34.75" | 37.25" | 30" | 30" | 30" | 4.25" | 1.5" |
| Paca-Waiter 500 lbs.  | 36"x36"x48"      | 20.75"                       | 40.75" | 43.25" | 36" | 36" | 36" | 4.25" | 1.5" |

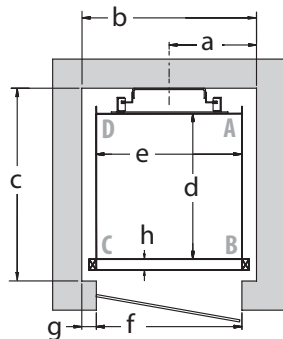

### FRONT OPENING (CB) Code 3

| Dumbwaiter Type       | GATED DUMBWAITER |                              |     |        |     |     |     |    |      |
|-----------------------|------------------|------------------------------|-----|--------|-----|-----|-----|----|------|
|                       | Car Size         | Finished Hoistway Dimensions |     |        |     |     |     |    |      |
| FRONT OPENING         |                  | a                            | b   | c      | d   | e   | f   | g  | h    |
| Cable-Waiter 50 lbs.  | 16"x16"x24"      | 10"                          | 21" | 22.25" | 16" | 16" | 16" | 3" | 1.5" |
| Cable-Waiter 100 lbs. | 20"x20"x30"      | 12"                          | 24" | 26.25" | 20" | 20" | 20" | 2" | 1.5" |
| Paca-Waiter 200 lbs.  | 26"x26"x36"      | 16"                          | 32" | 33"    | 26" | 26" | 26" | 3" | 1.5" |
| Paca-Waiter 300 lbs.  | 30"x30"x40"      | 18"                          | 36" | 37"    | 30" | 30" | 30" | 3" | 1.5" |
| Paca-Waiter 500 lbs.  | 36"x36"x48"      | 21"                          | 42" | 43"    | 36" | 36" | 36" | 3" | 1.5" |



# Hoistway Layout - Dumbwaiter

The dumbwaiters listed in the following section are based upon our standard car. Cars can be customized to meet your unique needs.

## Steel Car with Gates

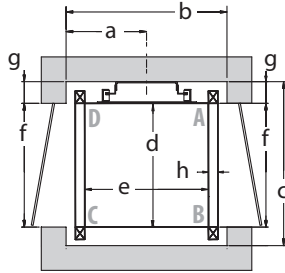

### OPPOSITE OPENINGS (AB DC) Code 4

| Dumbwaiter Type       | Car Size    | GATED DUMBWAITER             |       |        |     |     |     |       |      |
|-----------------------|-------------|------------------------------|-------|--------|-----|-----|-----|-------|------|
|                       |             | Finished Hoistway Dimensions |       |        |     |     |     |       |      |
| Opposite Openings     |             | a                            | b     | c      | d   | e   | f   | g     | h    |
| Cable-Waiter 50 lbs.  | 16"x16"x24" | 10.5"                        | 21.5" | 22.5"  | 16" | 16" | 16" | 3.5"  | 1.5" |
| Cable-Waiter 100 lbs. | 20"x20"x30" | 12.5"                        | 25.5" | 26.5"  | 20" | 20" | 20" | 3.5"  | 1.5" |
| Paca-Waiter 200 lbs.  | 26"x26"x36" | 15.5"                        | 31.5" | 33.25" | 26" | 26" | 26" | 4.25" | 1.5" |
| Paca-Waiter 300 lbs.  | 30"x30"x40" | 17.5"                        | 35.5" | 37.25" | 30" | 30" | 30" | 4.25" | 1.5" |
| Paca-Waiter 500 lbs.  | 36"x36"x48" | 20.5"                        | 41.5" | 43.25" | 36" | 36" | 36" | 4.25" | 1.5" |

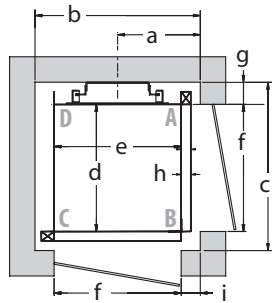

### RIGHT ADJACENT OPENINGS (AB CB) Code 5

| Dumbwaiter Type       | Car Size    | GATED DUMBWAITER             |        |        |     |     |     |       |      |    |
|-----------------------|-------------|------------------------------|--------|--------|-----|-----|-----|-------|------|----|
|                       |             | Finished Hoistway Dimensions |        |        |     |     |     |       |      |    |
| Right Adjacent Open   |             | a                            | b      | c      | d   | e   | f   | g     | h    | i  |
| Cable-Waiter 50 lbs.  | 16"x16"x24" | 10.75"                       | 21.75" | 22.25" | 16" | 16" | 16" | 3.5"  | 1.5" | 3" |
| Cable-Waiter 100 lbs. | 20"x20"x30" | 12.75"                       | 25.75" | 26.25" | 20" | 20" | 20" | 3.5"  | 1.5" | 3" |
| Paca-Waiter 200 lbs.  | 26"x26"x36" | 15.75"                       | 31.75" | 33"    | 26" | 26" | 26" | 4.25" | 1.5" | 3" |
| Paca-Waiter 300 lbs.  | 30"x30"x40" | 17.75"                       | 35.75" | 37"    | 30" | 30" | 30" | 4.25" | 1.5" | 3" |
| Paca-Waiter 500 lbs.  | 36"x36"x48" | 20.75"                       | 41.75" | 43"    | 36" | 36" | 36" | 4.25" | 1.5" | 3" |

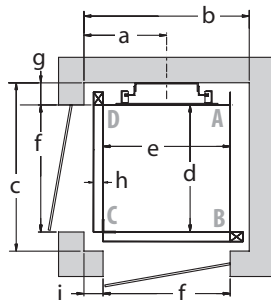

### LEFT ADJACENT OPENINGS (DC BC) Code 6

| Dumbwaiter Type       | Car Size    | GATED DUMBWAITER             |        |        |     |     |     |       |      |    |
|-----------------------|-------------|------------------------------|--------|--------|-----|-----|-----|-------|------|----|
|                       |             | Finished Hoistway Dimensions |        |        |     |     |     |       |      |    |
| Left Adjacent Open    |             | A                            | B      | C      | D   | E   | F   | G     | H    | I  |
| Cable-Waiter 50 lbs.  | 16"x16"x24" | 10.75"                       | 21.75" | 22.25" | 16" | 16" | 16" | 3.5"  | 1.5" | 3" |
| Cable-Waiter 100 lbs. | 20"x20"x30" | 12.75"                       | 25.75" | 26.25" | 20" | 20" | 20" | 3.5"  | 1.5" | 3" |
| Paca-Waiter 200 lbs.  | 26"x26"x36" | 15.75"                       | 31.75" | 33"    | 26" | 26" | 26" | 4.25" | 1.5" | 3" |
| Paca-Waiter 300 lbs.  | 30"x30"x40" | 17.75"                       | 35.75" | 37"    | 30" | 30" | 30" | 4.25" | 1.5" | 3" |
| Paca-Waiter 500 lbs.  | 36"x36"x48" | 20.75"                       | 41.75" | 43"    | 36" | 36" | 36" | 4.25" | 1.5" | 3" |



# Hoistway Layout - Dumbwaiter

The dumbwaiters listed in the following section are based upon our standard car. Cars can be customized to meet your unique needs.

## Steel Car with Gates and Commercial Doors

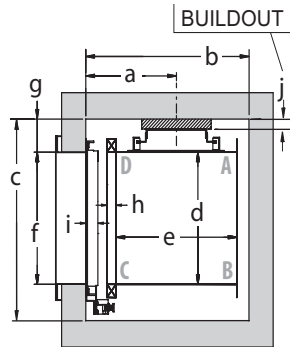

### LEFT OPENING (DC) Code 1

| Dumbwaiter Type       | GATED DUMBWAITER WITH COMMERCIAL DOOR |                              |        |       |     |     |     |    |      |    |      |
|-----------------------|---------------------------------------|------------------------------|--------|-------|-----|-----|-----|----|------|----|------|
|                       | Car Size                              | Finished Hoistway Dimensions |        |       |     |     |     |    |      |    |      |
| Left Opening          |                                       | a                            | b      | c     | d   | e   | f   | g  | h    | i  | j    |
| Cable-Waiter 50 lbs.  | 16"x16"x24"                           | 12.75"                       | 22.75" | 26.5" | 16" | 16" | 16" | 5" | 1.5" | 2" | 1.5" |
| Cable-Waiter 100 lbs. | 20"x20"x30"                           | 14.75"                       | 26.75" | 30.5" | 20" | 20" | 20" | 5" | 1.5" | 2" | 1.5" |
| Paca-Waiter 200 lbs.  | 26"x26"x36"                           | 17.75"                       | 32.75" | 36.5" | 26" | 26" | 26" | 5" | 1.5" | 2" | .75" |
| Paca-Waiter 300 lbs.  | 30"x30"x40"                           | 19.75"                       | 36.75" | 40.5" | 30" | 30" | 30" | 5" | 1.5" | 2" | .75" |
| Paca-Waiter 500 lbs.  | 36"x36"x48"                           | 22.75"                       | 42.75" | 46.5" | 36" | 36" | 36" | 5" | 1.5" | 2" | .75" |

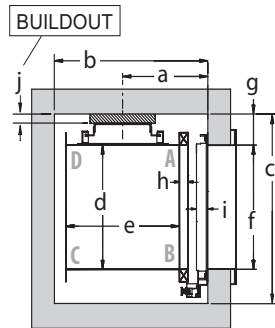

### RIGHT OPENING (AB) Code 2

| Dumbwaiter Type       | GATED DUMBWAITER WITH COMMERCIAL DOOR |                              |        |       |     |     |     |    |      |    |      |
|-----------------------|---------------------------------------|------------------------------|--------|-------|-----|-----|-----|----|------|----|------|
|                       | Car Size                              | Finished Hoistway Dimensions |        |       |     |     |     |    |      |    |      |
| Right Opening         |                                       | a                            | b      | c     | d   | e   | f   | g  | h    | i  | j    |
| Cable-Waiter 50 lbs.  | 16"x16"x24"                           | 12.75"                       | 23.75" | 26.5" | 16" | 16" | 16" | 5" | 1.5" | 2" | 1.5" |
| Cable-Waiter 100 lbs. | 20"x20"x30"                           | 14.75"                       | 26.75" | 30.5" | 20" | 20" | 20" | 5" | 1.5" | 2" | 1.5" |
| Paca-Waiter 200 lbs.  | 26"x26"x36"                           | 17.75"                       | 32.75" | 36.5" | 26" | 26" | 26" | 5" | 1.5" | 2" | .75" |
| Paca-Waiter 300 lbs.  | 30"x30"x40"                           | 19.75"                       | 36.75" | 40.5" | 30" | 30" | 30" | 5" | 1.5" | 2" | .75" |
| Paca-Waiter 500 lbs.  | 36"x36"x48"                           | 22.75"                       | 42.75" | 46.5" | 36" | 36" | 36" | 5" | 1.5" | 2" | .75" |

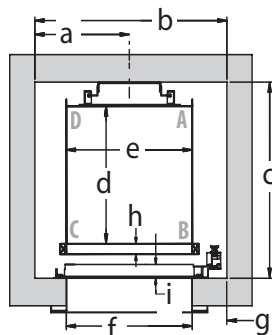

### FRONT OPENING (CB) Code 3

| Dumbwaiter Type       | GATED DUMBWAITER WITH COMMERCIAL DOOR |                              |       |        |     |     |     |      |      |    |
|-----------------------|---------------------------------------|------------------------------|-------|--------|-----|-----|-----|------|------|----|
|                       | Car Size                              | Finished Hoistway Dimensions |       |        |     |     |     |      |      |    |
| Front Opening         |                                       | a                            | b     | c      | d   | e   | f   | g    | h    | i  |
| Cable-Waiter 50 lbs.  | 16"x16"x24"                           | 13"                          | 26.5" | 24.25" | 16" | 16" | 16" | 5.5" | 1.5" | 2" |
| Cable-Waiter 100 lbs. | 20"x20"x30"                           | 15"                          | 30.5" | 28.25" | 20" | 20" | 20" | 5.5" | 1.5" | 2" |
| Paca-Waiter 200 lbs.  | 26"x26"x36"                           | 18"                          | 36.5" | 35"    | 26" | 26" | 26" | 5.5" | 1.5" | 2" |
| Paca-Waiter 300 lbs.  | 30"x30"x40"                           | 20"                          | 40.5" | 39"    | 30" | 30" | 30" | 5.5" | 1.5" | 2" |
| Paca-Waiter 500 lbs.  | 36"x36"x48"                           | 23"                          | 46.5" | 45"    | 36" | 36" | 36" | 5.5" | 1.5" | 2" |



# Hoistway Layout - Dumbwaiter

The dumbwaiters listed in the following section are based upon our standard car. Cars can be customized to meet your unique needs.

## Steel Car with Gates and Commercial Doors

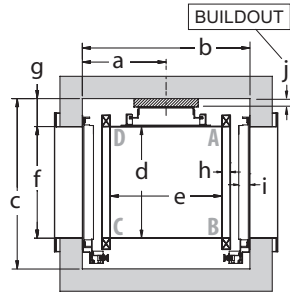

### OPPOSITE OPENINGS (AB DC) Code 4

| Dumbwaiter Type       | GATED DUMBWAITER WITH COMMERCIAL DOOR |                              |       |       |     |     |     |    |      |    |      |
|-----------------------|---------------------------------------|------------------------------|-------|-------|-----|-----|-----|----|------|----|------|
|                       | Car Size                              | Finished Hoistway Dimensions |       |       |     |     |     |    |      |    |      |
| Opposite Opening      |                                       | a                            | b     | c     | d   | e   | f   | g  | h    | i  | j    |
| Cable-Waiter 50 lbs.  | 16"x16"x24"                           | 12.5"                        | 25.5" | 26.5" | 16" | 16" | 16" | 5" | 1.5" | 2" | 1.5" |
| Cable-Waiter 100 lbs. | 20"x20"x30"                           | 14.5"                        | 29.5" | 30.5" | 20" | 20" | 20" | 5" | 1.5" | 2" | 1.5" |
| Paca-Waiter 200 lbs.  | 26"x26"x36"                           | 17.5"                        | 35.5" | 36.5" | 26" | 26" | 26" | 5" | 1.5" | 2" | .75" |
| Paca-Waiter 300 lbs.  | 30"x30"x40"                           | 19.5"                        | 39.5" | 40.5" | 30" | 30" | 30" | 5" | 1.5" | 2" | .75" |
| Paca-Waiter 500 lbs.  | 36"x36"x48"                           | 22.5"                        | 45.5" | 46.5" | 36" | 36" | 36" | 5" | 1.5" | 2" | .75" |

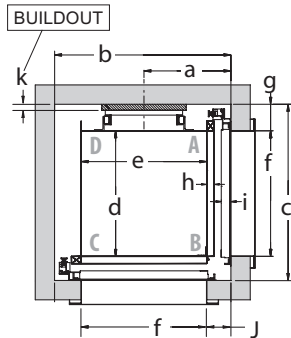

### RIGHT ADJACENT OPENINGS (AB CB) Code 5

| Dumbwaiter Type      | GATED DUMBWAITER WITH COMMERCIAL DOOR |                              |        |        |     |     |     |      |      |    |    |       |
|----------------------|---------------------------------------|------------------------------|--------|--------|-----|-----|-----|------|------|----|----|-------|
|                      | Car Size                              | Finished Hoistway Dimensions |        |        |     |     |     |      |      |    |    |       |
| Right Adjacent Open  |                                       | a                            | b      | c      | d   | e   | f   | g    | h    | i  | j  | k     |
| Paca-Waiter 200 lbs. | 26"x26"x36"                           | 17.75"                       | 36.25" | 36.25" | 26" | 26" | 26" | 5.5" | 1.5" | 2" | 5" | 1.25" |
| Paca-Waiter 300 lbs. | 30"x30"x40"                           | 19.75"                       | 40.25" | 40.25" | 30" | 30" | 30" | 5.5" | 1.5" | 2" | 5" | 1.25" |
| Paca-Waiter 500 lbs. | 36"x36"x48"                           | 22.75"                       | 46.25" | 46.25" | 36" | 36" | 36" | 5.5" | 1.5" | 2" | 5" | 1.25" |

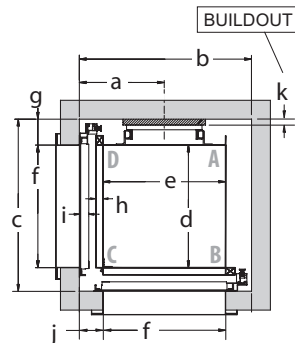

### LEFT ADJACENT OPENINGS (DC BC) Code 6

| Dumbwaiter Type      | GATED DUMBWAITER WITH COMMERCIAL DOOR |                              |        |        |     |     |     |      |      |    |    |       |
|----------------------|---------------------------------------|------------------------------|--------|--------|-----|-----|-----|------|------|----|----|-------|
|                      | Car Size                              | Finished Hoistway Dimensions |        |        |     |     |     |      |      |    |    |       |
| Left Adjacent Open   |                                       | a                            | b      | c      | d   | e   | f   | g    | h    | i  | j  | k     |
| Paca-Waiter 200 lbs. | 26"x26"x36"                           | 17.75"                       | 36.25" | 36.25" | 26" | 26" | 26" | 5.5" | 1.5" | 2" | 5" | 1.25" |
| Paca-Waiter 300 lbs. | 30"x30"x40"                           | 19.75"                       | 40.25" | 40.25" | 30" | 30" | 30" | 5.5" | 1.5" | 2" | 5" | 1.25" |
| Paca-Waiter 500 lbs. | 36"x36"x48"                           | 22.75"                       | 46.25" | 46.25" | 36" | 36" | 36" | 5.5" | 1.5" | 2" | 5" | 1.25" |



# Elevation Layout - Cable-Waiter

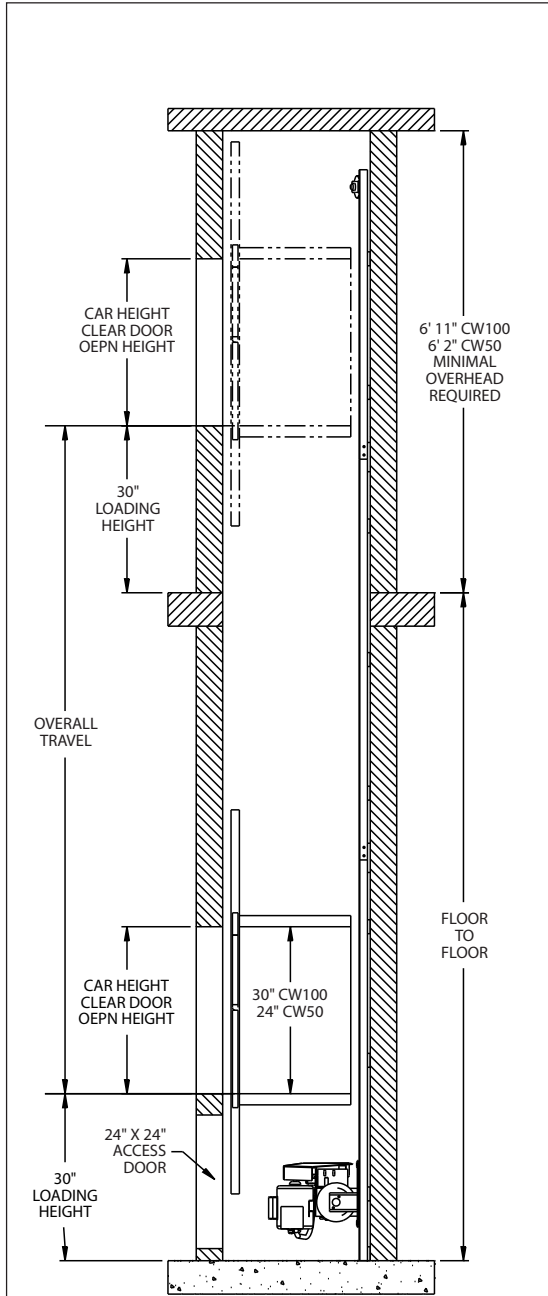

## Rail Below Car w/Top Mount Sheave

For additional information and dimensions contact your local dealer.

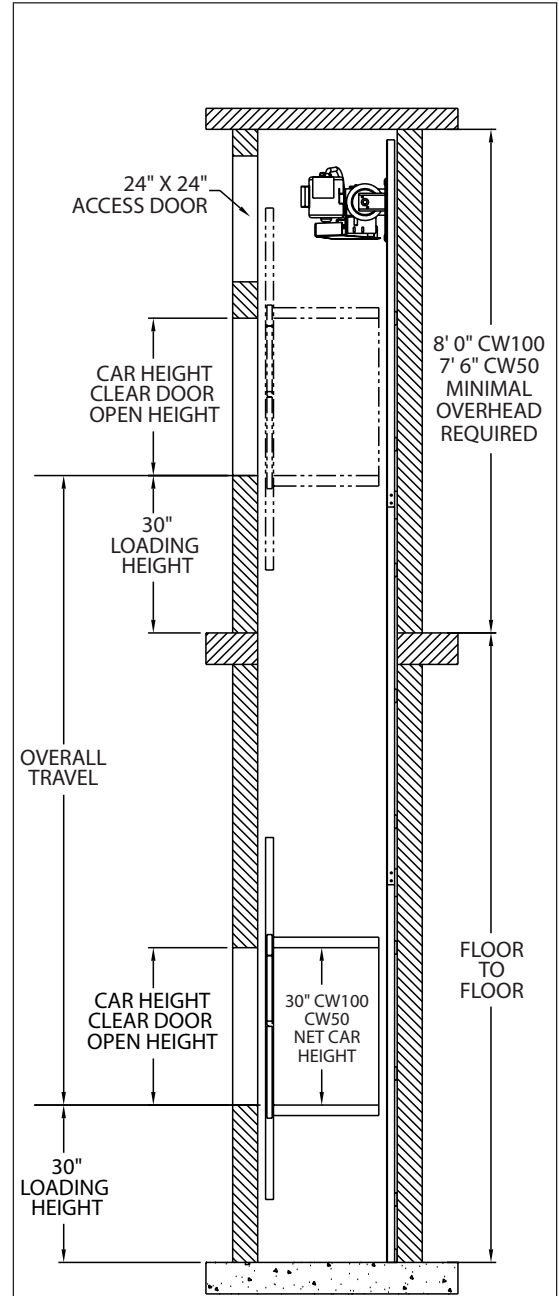

## Rail Above Car

For additional information and dimensions contact your local dealer.



# Elevation Layout - Paca-Waiter

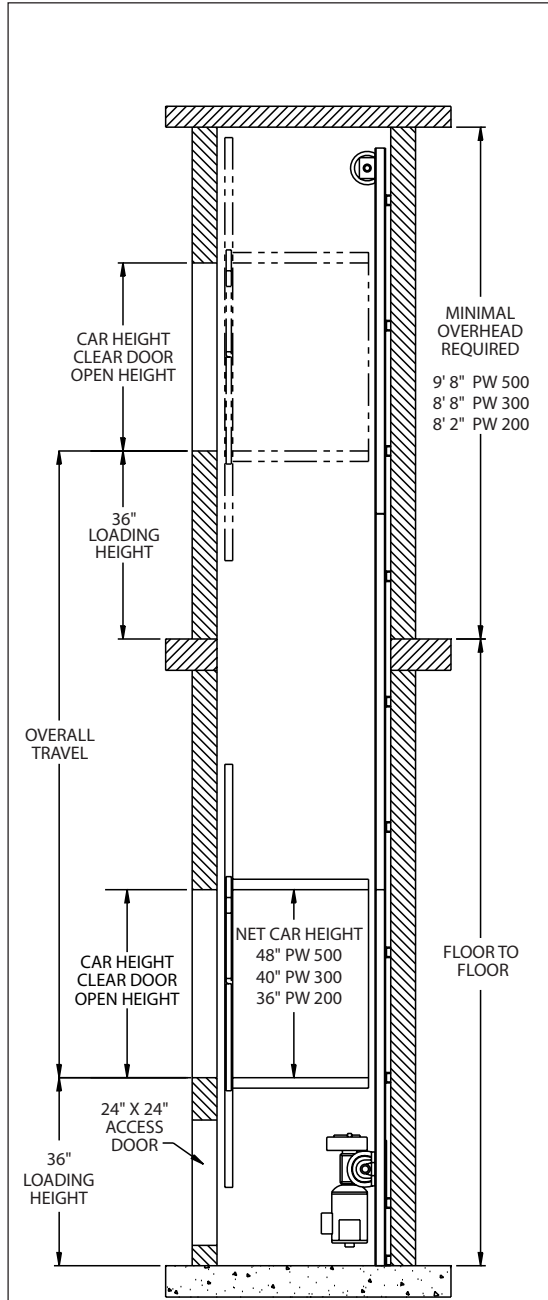

## Rail Below Car w/Travel Sheave

For additional information and dimensions contact your local dealer.

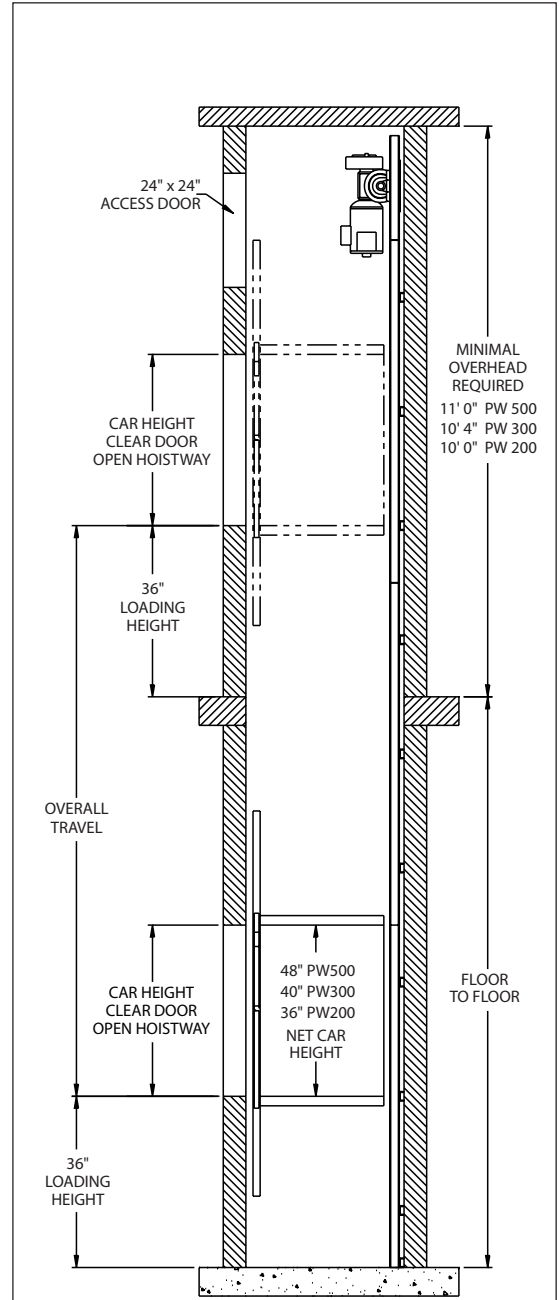

## Rail Above Car

For additional information and dimensions contact your local dealer.



# Elevation Layout for Bi-Parting Doors

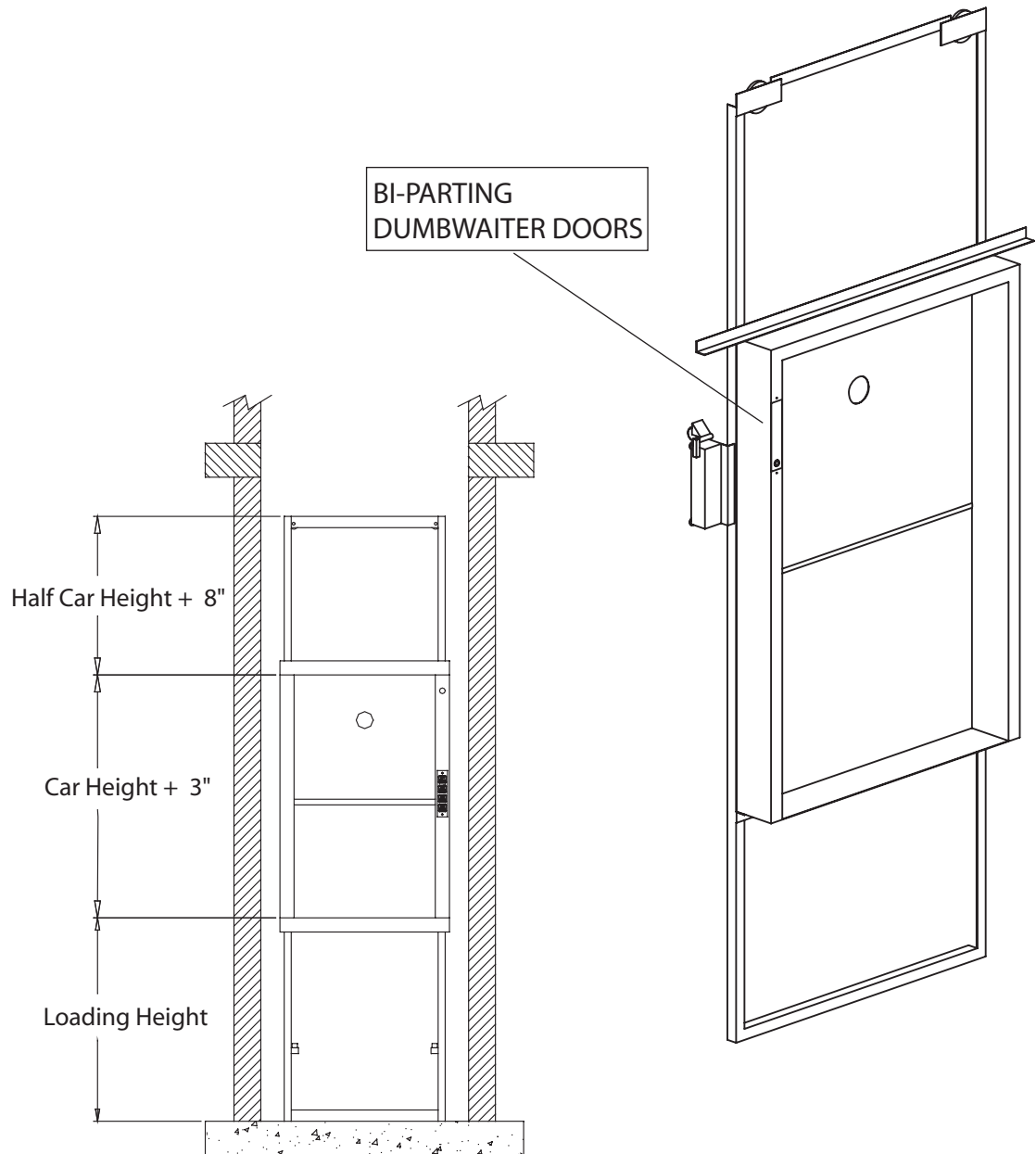

**Note:**  
Recommended to leave entire hoistway  
wall open for door installation



# Dumbwaiter Equipment

## Typical

- Powerhead
- Main Rail
- Gear Box
- Sheaves
- Interlocks
- Motor
- Drum

### CABLE-WAITER

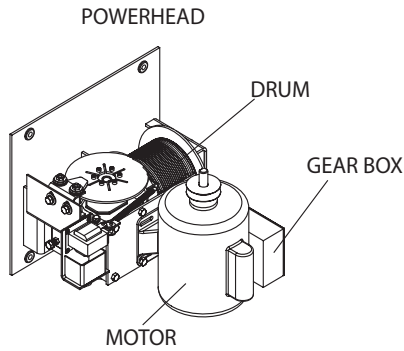

### PACA-WAITER

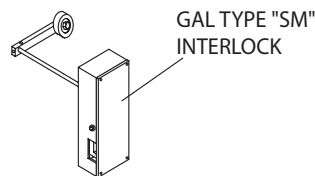
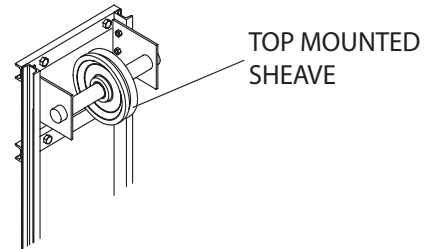
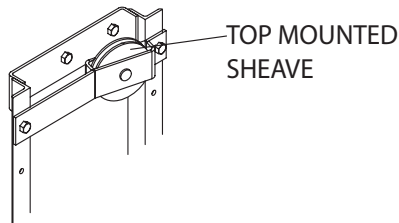
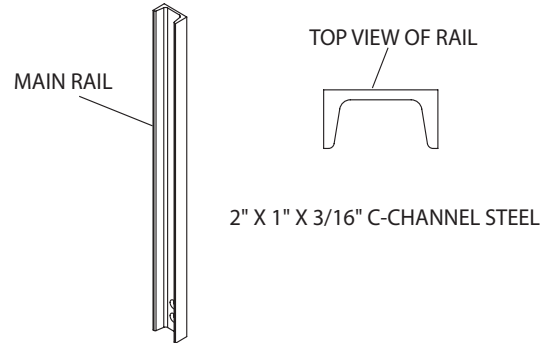
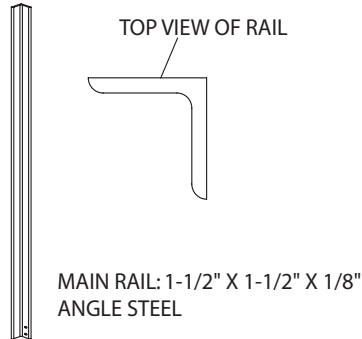
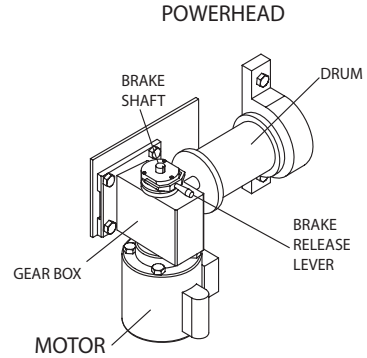

HOISTWAY DOOR INTERLOCKS  
EMI OR GAL TYPE "SM" REQUIRED  
AT EACH OPENING TO PREVENT  
HOISTWAY OR DUMBWAITER  
ACCESS WHILE DUMBWAITER  
IS OPERATING OR AT ANOTHER  
LANDING.

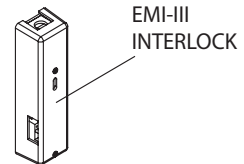

# Cable-Waiter Series 007

## Paca-Waiter Series 011

CABLE-WAITER

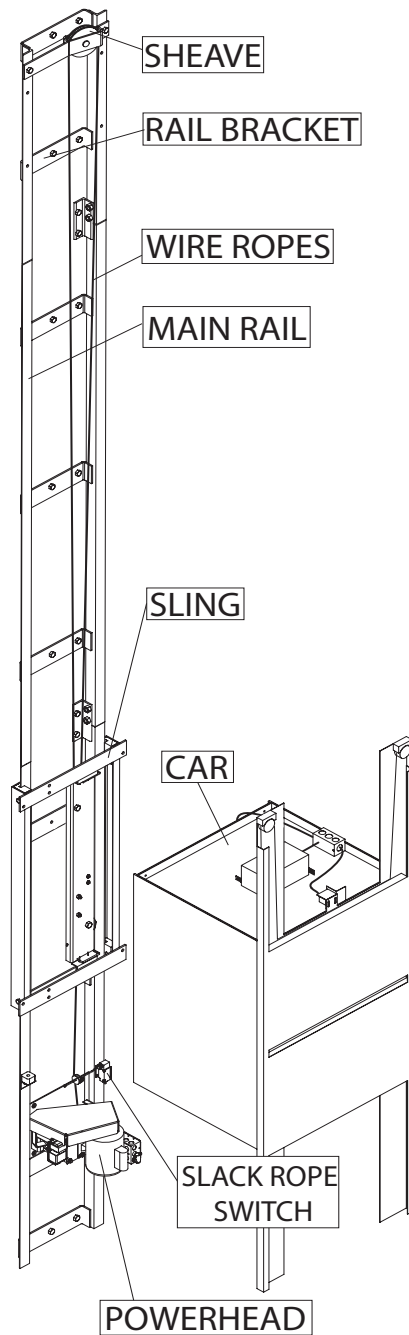

PACA-WAITER

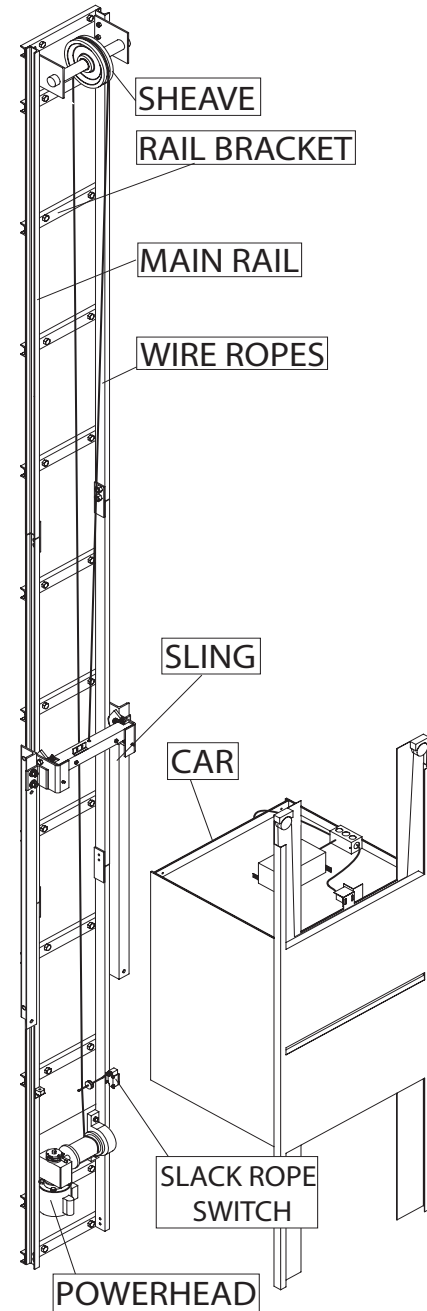



PMQ0400-A  
MAY 2008

1726 North Ballard Road • Appleton, WI 54911  
Phone 920-991-9082 • [www.waupacaelevator.com](http://www.waupacaelevator.com)

