



WAUPACA
ELEVATOR COMPANY, INC.
Specify the Specialists®

Planning Guide

Paca-Glide
Elevator





We are a proud member of the Accessibility Equipment Manufacturers Association. This symbol assures you of our commitment to high quality and accessibility to everyone.



Waupaca Elevator Mission Statement

Our company’s mission is to supply and service products that meet or exceed our customers’ expectations of high quality, value, delivery and longevity. Our success is a direct reflection of our employees’ involvement and commitment to excellence. We strive to continuously improve our products to ensure meeting the future requirements of our customers and facilitate competitive growth.

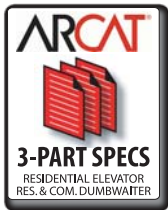

CSI 3-Part Specifications

Customize and download CSI 3-Part Specifications by logging on to:

www.arcat.com - specify Waupaca Elevator as the requested manufacturer

www.waupacaelevator.com - go to “Architect Section” click on linking icon



SpecWizard is a faster easier way to customize CSI 3-part residential elevator specifications. Follow the above website information and choose the Spec Wizard icon. The drop down menus couldn’t be any easier to use, just click on your choice of listed options and within a couple of minutes you have a completely customized specification.

Table of Contents

- Introduction 4
- Minimum - Maximum Dimensions 6
- Car Opening Configurations 6
- Hoistway Layout and Dimensions 7-9
- Hoistway Illustration 10
- Hoistway Specifications 11
- Elevation and Hoistway Ceiling Height 12
- Controller/Electrical Space 13
- Elevator Equipment 14
- Elevator Series 015 Illustration 15



Introduction

This Planning Reference Guide is to be used as a guide in deciding the type of elevator to be installed, parameters of installation and steps taken to achieve a proper elevator installation. This guide may be used by the architect, contractor, dealer or home owner. The information in this guide is intended as an overview, each installation will have job specific specifications that must be followed. Do not attempt to construct a hoistway on this information alone.

Elevator installation is to be done by an authorized elevator contractor, and in accordance with installation instructions provided by the manufacturer. Installation must also be in compliance with requirements of the National Electric Code, American Society of Mechanical Engineers safety code, and state and local building codes. Waupaca Elevator's products are designed to meet the requirements of ASME - 17.1 National Elevator Codes for residential elevators and are fully certified by a registered professional engineer. Waupaca Elevator Company, Inc. elevators manufactured and installed under the proper parameters are warranted for 2 years. Manufacturer assumes no liability for equipment not installed in compliance with these codes.

Planning Steps

1. - Locate local dealer and together determine the following:
 - A - Select drive system, car type and design specifications
 - B - Address national, state and local code requirements
 - C - Hoistway size
 - D - Car size, layout and options
 - E - Machine room location and layout (if required)
 - F - Electrical requirements
2. - Obtain and follow site specific field drawings while building hoistway, doorways and any other construction related to the elevator.
3. - Coordinate with dealer to install elevator.



Paca-Glide

Winding Drum Elevator

Machine Room Less

Series **015**

Advantages

- No Machine Room Required
- Decreased Installation Time
- Advanced Fieldbus Electrical System
- Reliable
- Quiet Operation
- Smooth Ride
- Emergency Battery Descent
- Automatic Gate Operator



Hoistway Layout - Paca-Glide

Minimum and Maximum Dimensions

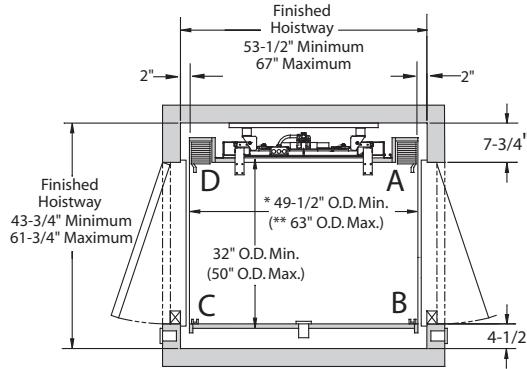

* Single Opening - 42 - 3/4" O.D. (outside dimension) **minimum** (rail is not centered in hoistway)

** Single Opening - 62-1/2" O. D. (outside dimensions) **maximum**

- NOTE:**
- 1) Minimum **D A** dimensions reflect rail centered in hoistway
 - 2) Minimum **D A** dimension for car without a gate recess is 36" O.D. (outside dimension)
 - 3) Car I.D. (inside dimensions) can not exceed 15 sq. ft. for 1,000 lb.

Car Opening Configurations and Coding

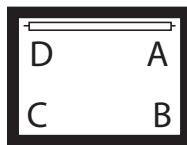
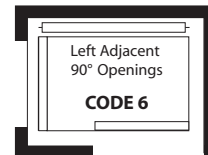
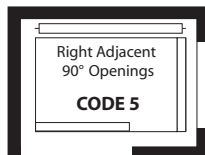
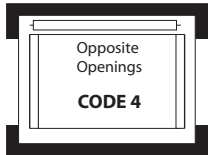
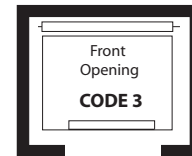
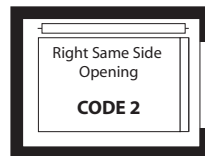
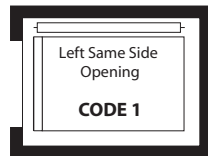

- 1- The D A is the side on which the rail is attached.
- 2 - The first letter refers to the attachment location of the gate.
- 3 - The second letter refers to the location of the strike plate.
- 4 - If present, the third letter "R" denote a recessed gate.

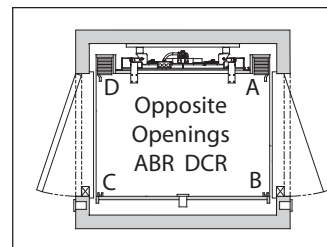

Example: ABR DCR

- | | |
|---------------------|---------------------|
| First Gate - ABR | Second Gate - DCR |
| A - gate attachment | D - gate attachment |
| B - strike plate | C - strike plate |
| R - recessed gate | R - recessed gate |

Hoistway Layout - Paca-Glide

- Use specified rail backing from architect to frame into wall.
- Hoistway illustrations below show finished dimensions. Finished hoistway dimensions include drywall, plaster and paint.
- A maximum of 3" (see "g" below) are allowed between the closed hoistway door and the outer edge of the landing sill.
- Determine height of hall station by local code.
- Rough frame door in place with an extra inch of space on each side of the door to allow for door installation.

The following examples are of a 1,000 lb. unit. Elevators are illustrated with accordion gates. The following layouts were designed for travel less than 25 feet, for distances up to 50 feet contact Waupaca Elevator Co.

These symbols are listed beside the car size Waupaca Elevator believes to be best suited for use by wheelchair passengers and their accompanying attendant.



Recommended size for wheelchair passenger



Recommended size for both wheelchair and attendant passengers

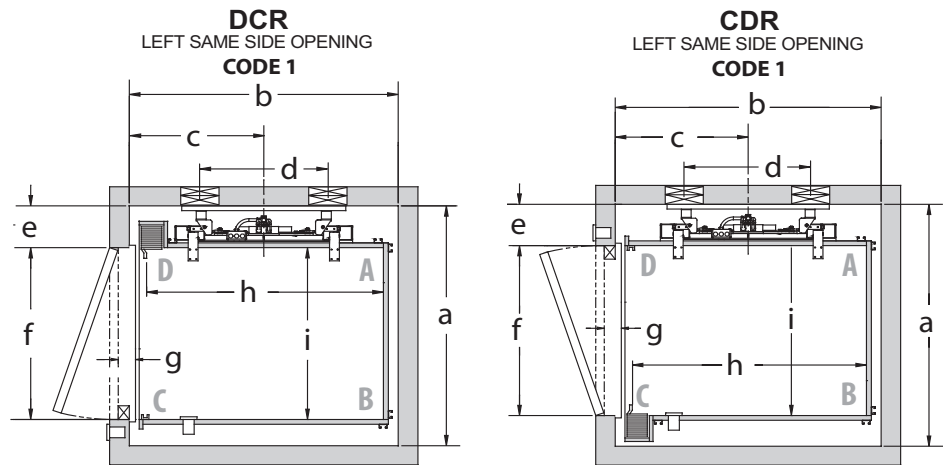

ELEVATOR HOISTWAY LAYOUT		PACA GLIDE/LIFT ELEVATOR HOISTWAY DIMENSIONS									
		CAR SIZE	FINISHED HOISTWAY DIMENSIONS								
			a	b	c	d	e	f	g	h	i
CODE 1 LEFT SAME SIDE OPENING	DCR	48" x 36"	50.25"	54.5"	27.25"	24.5"	8.75"	36"	3"	48"	36"
	DCR	54" x 40"	54.25"	60.5"	30.25"	24.5"	12.75"	36"	3"	54"	40"
	DCR	60" x 36"	50.25"	66.5"	33.25"	24.5"	8.75"	36"	3"	60"	36"
CODE 1 LEFT SAME SIDE OPENING	CDR	48" x 36"	51.25"	54.5"	27.25"	24.5"	8.75"	36"	3"	48"	36"
	CDR	54" x 40"	53.75"	60.5"	30.25"	24.5"	8.75"	36"	3"	54"	40"
	CDR	60" x 36"	51.25"	66.5"	33.25"	24.5"	8.75"	36"	3"	60"	36"



Hoistway Layout - Paca-Glide

ABR
RIGHT SAME SIDE OPENING
CODE 2

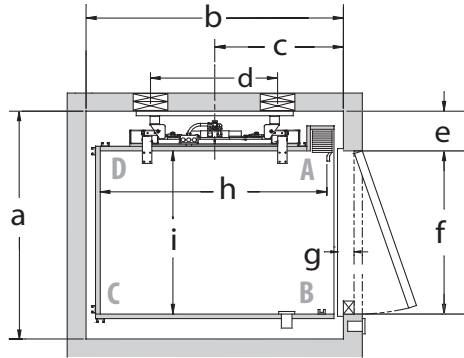

BAR
RIGHT SAME SIDE OPENING
CODE 2

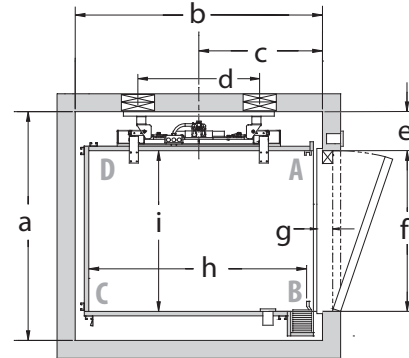

ELEVATOR HOISTWAY LAYOUT	PACA GLIDE/LIFT ELEVATOR HOISTWAY DIMENSIONS									
	CAR SIZE	FINISHED HOISTWAY DIMENSIONS								
		a	b	c	d	e	f	g	h	i
CODE 2 RIGHT SAME SIDE OPENING	ABR	48" x 36"	50.25"	54.5"	27.25"	24.5"	8.75"	36"	3"	48" 36"
	ABR	54" x 40"	54.25"	60.5"	30.25"	24.5"	12.75"	36"	3"	54" 40"
	ABR	60" x 36"	50.25"	66.5"	33.25"	24.5"	8.75"	36"	3"	60" 36"
CODE 2 RIGHT SAME SIDE OPENING	BAR	48" x 36"	51.25"	54.5"	27.25"	24.5"	8.75"	36"	3"	48" 36"
	BAR	54" x 40"	53.75"	60.5"	30.25"	24.5"	8.75"	36"	3"	54" 40"
	BAR	60" x 36"	51.25"	66.5"	33.25"	24.5"	8.75"	36"	3"	60" 36"

BC
LEFT FRONT OPENING
CODE 3

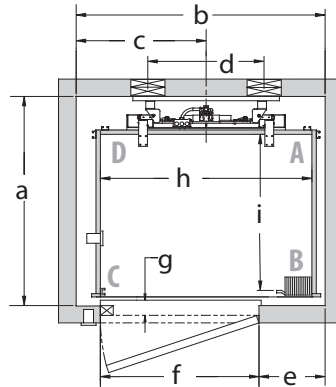

CB
RIGHT FRONT OPENING
CODE 3

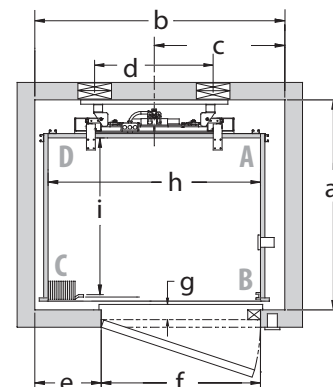

ELEVATOR HOISTWAY LAYOUT	PACA GLIDE/LIFT ELEVATOR HOISTWAY DIMENSIONS									
	CAR SIZE	FINISHED HOISTWAY DIMENSIONS								
		a	b	c	d	e	f	g	h	i
CODE 3 LEFT FRONT OPENING	BC	48" x 36"	48.25"	56.5"	29.5"	24.5"	15"	36"	3"	48" 36"
	BC	54" x 40"	52.25"	62.5"	32.5"	24.5"	21"	36"	3"	54" 40"
	BC	60" x 36"	48.25"	68.5"	35.5"	24.5"	27"	36"	3"	60" 36"
CODE 3 RIGHT FRONT OPENING	CB	48" x 36"	48.25"	56.5"	29.5"	24.5"	15"	36"	3"	48" 36"
	CB	54" x 40"	52.25"	62.5"	32.5"	24.5"	21"	36"	3"	54" 40"
	CB	60" x 36"	48.25"	68.5"	35.5"	24.5"	27"	36"	3"	60" 36"



Hoistway Layout - Paca-Glide

ABR - DCR
OPPOSITE OPENING
CODE 4

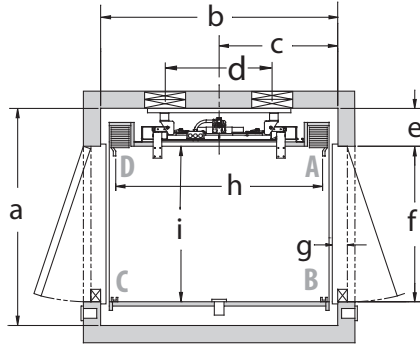

BAR - CDR
OPPOSITE OPENING
CODE 4

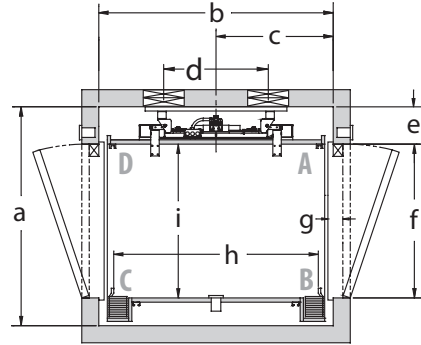

ELEVATOR HOISTWAY LAYOUT	CAR SIZE	PACA GLIDE/LIFT ELEVATOR HOISTWAY DIMENSIONS									
		FINISHED HOISTWAY DIMENSIONS									
		a	b	c	d	e	f	g	h	i	
CODE 4 OPPOSITE OPENING	ABR-DCR	48" x 36"	50.25"	55"	27.50"	24.5"	8.75"	36"	3"	48"	36"
	ABR-DCR	54" x 40"	54.25"	61"	30.50"	24.5"	12.75"	36"	3"	54"	40"
	ABR-DCR	60" x 36"	50.25"	67"	33.50"	24.5"	8.75"	36"	3"	60"	36"
CODE 4 OPPOSITE OPENING	BAR-CDR	48" x 36"	51.25"	55"	27.50"	24.5"	8.75"	36"	3"	48"	36"
	BAR-CDR	54" x 40"	53.75"	61"	30.50"	24.5"	8.75"	36"	3"	54"	40"
	BAR-CDR	60" x 36"	51.25"	67"	33.50"	24.5"	8.75"	36"	3"	60"	36"

ABR BC
RIGHT ADJACENT 90° OPENINGS
CODE 5

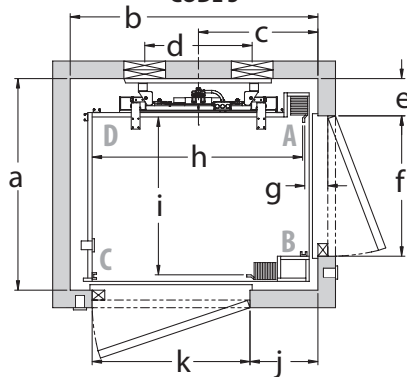

DCR-CB
LEFT ADJACENT 90° OPENINGS
CODE 6

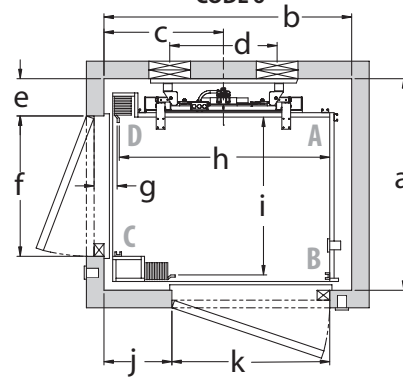

ELEVATOR HOISTWAY LAYOUT	CAR SIZE	PACA GLIDE/LIFT ELEVATOR HOISTWAY DIMENSIONS											
		FINISHED HOISTWAY DIMENSIONS											
		a	b	c	d	e	f	g	h	i	j	k	
CODE 5 RIGHT ADJACENT 90° OPENING	ABR-BC	48" x 36"	48.25"	56.5"	27.25"	24.5"	8.5"	32"	3"	48"	36"	15.5"	36"
	ABR-BC	54" x 40"	52.25"	62.5"	30.25"	24.5"	8.5"	36"	3"	54"	40"	21.5"	36"
	ABR-BC	60" x 36"	48.25"	68.5"	33.25"	24.5"	8.5"	32"	3"	60"	36"	27.5"	36"
CODE 6 LEFT ADJACENT 90° OPENING	DCR-CB	48" x 36"	48.25"	56.5"	27.25"	24.5"	8.5"	32"	3"	48"	36"	15.5"	36"
	DCR-CB	54" x 40"	52.25"	62.5"	30.25"	24.5"	8.5"	36"	3"	54"	40"	21.5"	36"
	DCR-CB	60" x 36"	48.25"	68.5"	33.25"	24.5"	8.5"	32"	3"	60"	36"	27.5"	36"



Hoistway Illustrations - Paca-Glide

The typical layouts shown here may vary from your actual hoistway. The purpose of these layouts are for a general understanding. Please refer to the Waupaca Elevator drawings and specifications that will be provided by the company.

This example applies to units with up to 25' of travel. Contact Waupaca Elevator for requirements on units traveling over 25.'

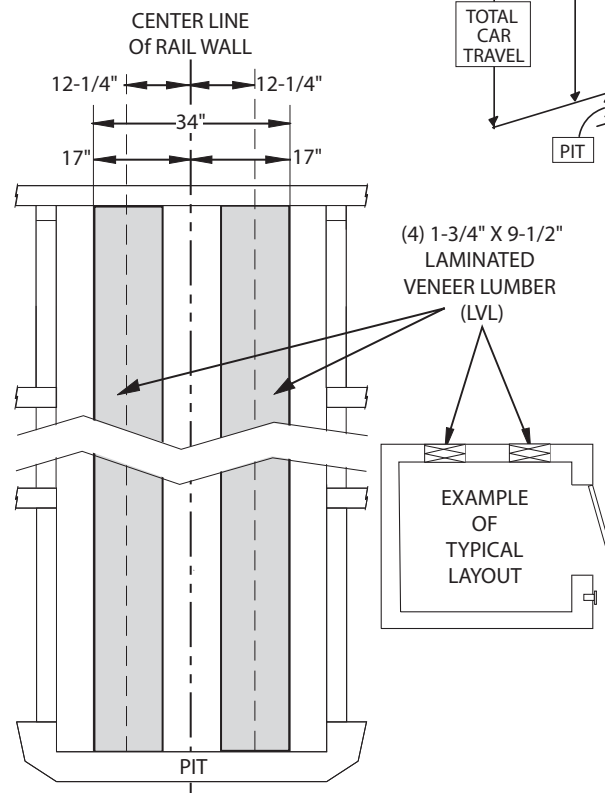
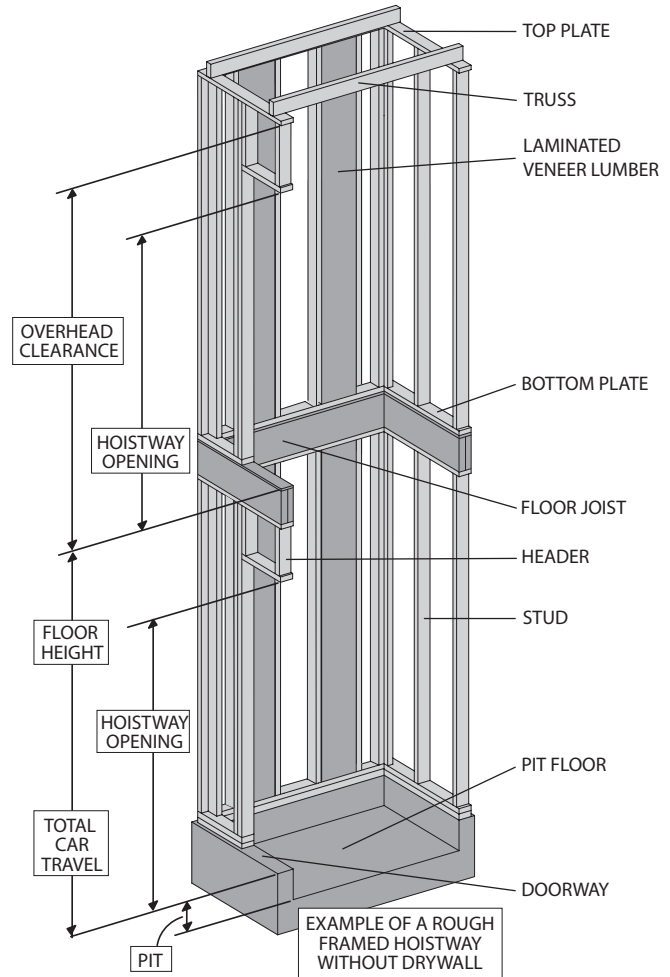

These drawings depict sample construction only. It is the responsibility of the installer/contractor or engineer to design and specify structural supports. All construction to be in compliance with local codes.



Hoistway Specifications - Paca-Glide

Refer to Illustration on previous page

ATTENTION CONSTRUCTION CONTRACTOR:

This is an example of a winding drum hoistway. Job specific documentation will be provided by Waupaca Elevator from which to construct the hoistway.

Hoistway Construction Requirements

(to be completed prior to elevator installation by contractor)

- 1. Electrical Requirements:**
 - Dedicated 230 VAC 30 AMP Circuit Single Phase. Fuse should be a time delay 25 AMP.
 - Power supply to be installed in a lockable fused disconnect.
 - 120 VAC 15 Amp Circuit Single Phase with manual disconnect & 15 AMP protection.
 - Electrical wiring to comply with applicable codes.
- 2. Unfinished/Un-installed Door** - Installation company may prefer a minimum of one hoistway door and associated framing be left unfinished/un-installed to accommodate elevator installation equipment and to prevent accidental damage to door and framing (preferably at grade level).
- 3. Plumb and Square Hoistway** - Hoistway must be plumb within 1/8 inch per 10 ft. of height and square at any point within 1/4 inch based on difference in diagonal measurements.
- 4. Supportive Structure** - Structure must be capable of supporting the appropriate loads. Local engineering support is recommended.
- 5. Telephone Connection** - Code requires a telephone connection to the elevator car, therefore, a phone line must be installed leading to the controller.
- 6. ASME 17.1 Part 5.3** - Hoistway to be constructed in accordance with ASME17.1 Part 5.3 and all local codes.
- 7. Hoistway Door Security (Interlocks)** - All hoistway doors require interlocks as well as a door handle and a latch set. Interlocks will be installed by the elevator installers. Waupaca Elevator recommends the use of solid core doors.
- 8. Temperature Requirements** - Hoistway and machine room temperature should be maintainable between 60° F- 110° F and should not be exposed to the elements.
- 9. No Alterations** - Any alterations to the equipment without written authorization by Waupaca Elevator will void all warranties.
- 10. Pit Floor Strength** - A pit floor must be designed to withstand a load of 4,000 lbs. When used, concrete must be a minimum of 4" thick and rated at 3500PSI.



Elevation and Hoistway Ceiling Heights - Paca-Glide

Since the Paca-Glide Power Unit sits on top of the rail, the hoistway will need to be taller than other winding drum or hydraulic units.

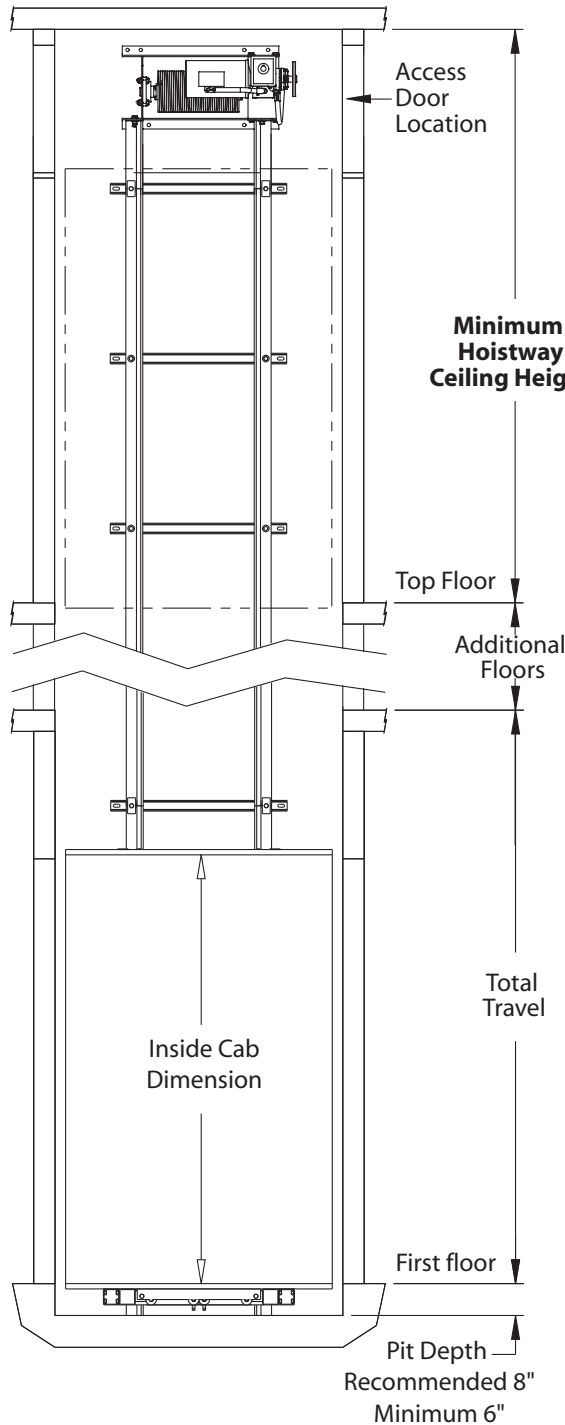

Structure required to support lifting drive and rail during installation. Locate near center of shaft (by others) minimum 1,000 lbs.

Additional space may be required for hoisting and maneuvering equipment into place. Waupaca Elevator will provide you with the appropriate dimensions.

Waupaca Elevator's Paca Glide offers a total of five stops and a total travel distance of 50 feet.

Hoistway Ceiling Heights*

Inside Cab Dimension	6' 10"	7' 0"	7' 4"	8' 0"
Recommended Ceiling Height	9' 0"	9' 2"	9' 6"	10' 2"
Minimum Ceiling Height	8' 10"	9' 0"	9' 4"	10' 0"

* Custom sized cabs will alter these dimensions. Waupaca Elevator will provide you with the appropriate dimensions.



Controller Space - Paca-Glide

Typical Layout

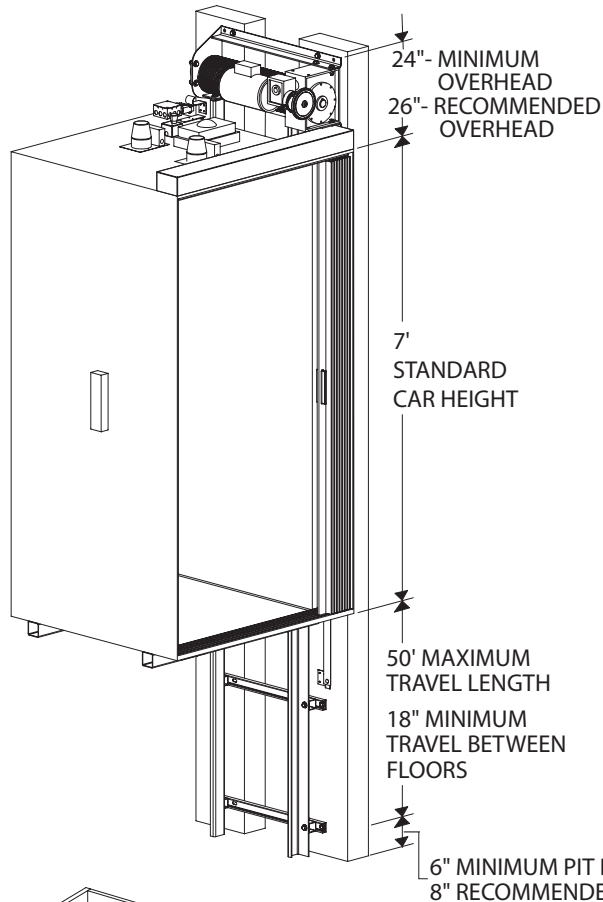

1. The Controller requires a clear minimum space of 36" x 30" located directly in front of the controller (refer to illustration).
2. A lockable service disconnect must be placed within sight of the controller and must be easily accessible, from the latch side of the doorway (if door is present).
3. Controller Space must be provided for the operating equipment that meets national electrical code clear space requirements and all local codes. Must provide a convenience outlet and light with switch. Temperatures must be maintained between 60°-110°F (with a relative humidity not to exceed 95%).

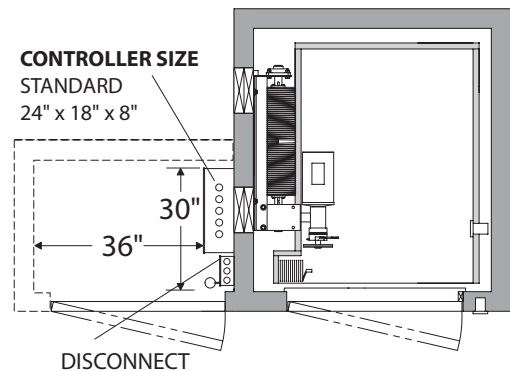
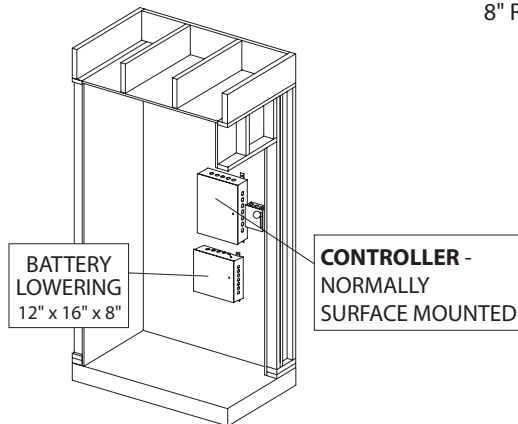

Elevator Equipment - Paca-Glide

Typical

- Powerhead
- Interlocks
- Main Rail
- Motor
- Gear Box
- Drum

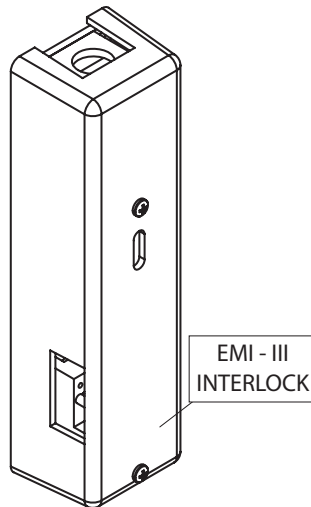
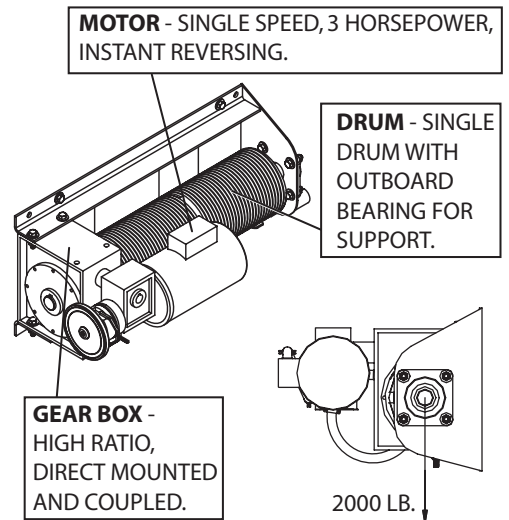
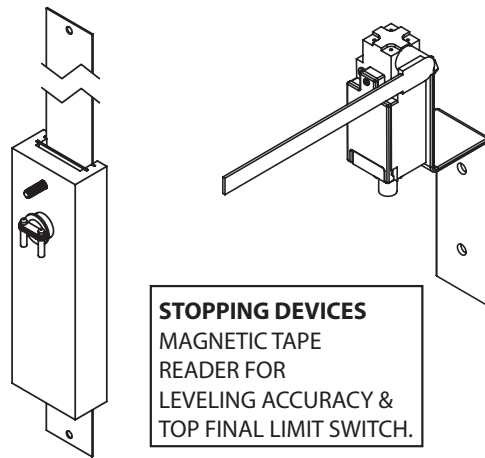

HOISTWAY DOOR INTERLOCKS EMI required at each opening to prevent hoistway or elevator access while elevator is operating or at another landing.

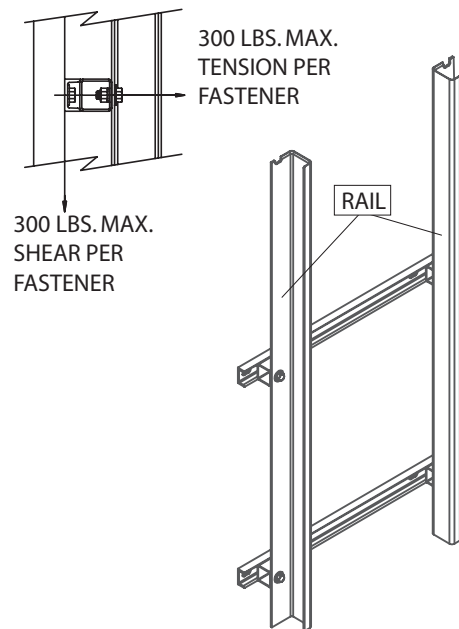

Paca-Glide Elevator Series 015

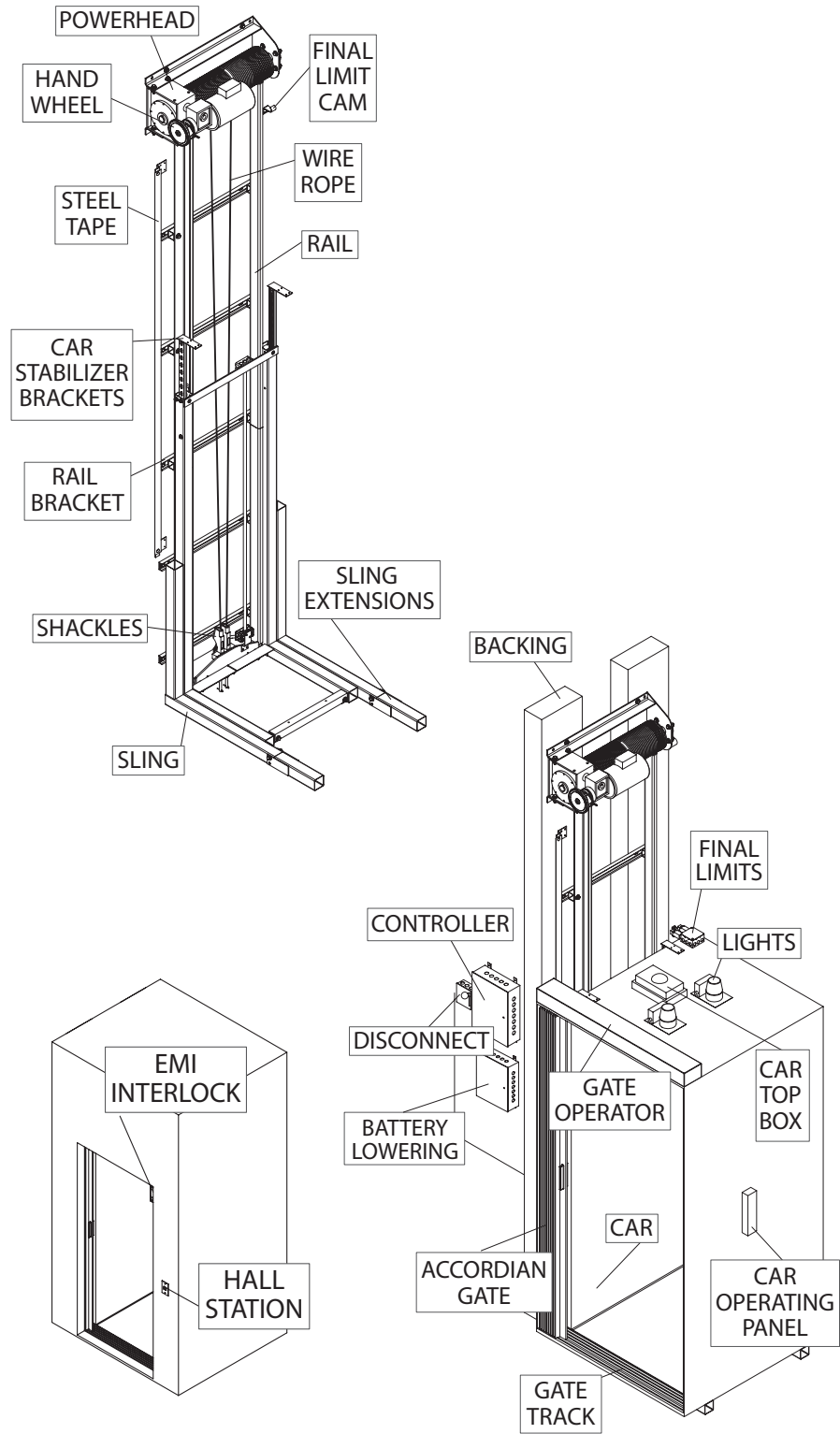



PMQ0300-B
APRIL 2008

1726 North Ballard Road • Appleton, WI 54911
Phone 920-991-9082 • www.waupacaelevator.com

