

Versa Lift TM

Attic Storage Lifting System

Patent Pending

Specification Guide

Versa Lift Models: 32, 32H, 32HX
with 15-ft. Corded Remote Control

Revised 2-4-2009

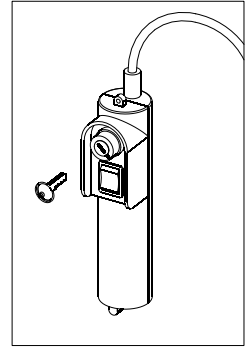

Remote w/15' Cord

The Versa Lift electric storage lift is designed to move cargo between adjacent floors. The lift's power head mounts over an opening in the upper floor. When ascending, the lifting platform automatically stops level with the upper floor. When descending, the lifting platform automatically stops upon contacting the lower floor. The control switch operation is momentary and the motor brake is applied instantly whenever the switch is released. The platform assembly includes a spring biased door panel that automatically covers the underside of the opening whenever the platform is fully raised. This door is self-adjusting for joists up to 18" in height and can easily be sealed with common weatherstripping.

Installation Requirements:

- Opening Required:** 30 1/2 x 58 1/2" (+1/2", -0")
- Opening Finish:** Smooth perpendicular sidewalls
- Electrical:** 115 vac grounded power outlet

Installation Recommendations:

The Lift's electrical outlet and the attic lighting should preferably be on a single circuit controlled by a switch outside of the attic. The opening should be close enough to the attic ladder so the remote control will reach through the ladder opening. For more detailed information and for specific framing suggestions, see the Rough-In Guide and the Versa Lift Installation Guide.

Specifications:

- Control:** Hand-held remote with 15' cord & keylock
- Floor-to-Floor:** 32=8-11', 32H=11-14', 32HX=14-20'
- Joist Height Max:** 18" (incl. decking & sheet rock)
- Lifting Capacity:** 35 Cu. Ft., 250 lbs. per load
- Platform Dimensions:** 28-3/4" x 56"
- Lift Speed:** 8"/sec. (10-ft. in approx. 15 seconds)
- Cables (2):** .093 steel w/zinc plating 1,000 lb. break
- Construction:** Powder coated steel
- Motor:** .6 HP Gear motor with automatic brake
- Voltage/Power:** 115 vac, 60 hz, 4.5 amps
- Power-head Dim.:** 34W x 69L x 60H
- Opening Required:** 30 1/2 x 58 1/2" (+1/2", -0")
- Opening Finish:** Smooth perpendicular sidewalls
- Shipping Weight:** 206 lbs.

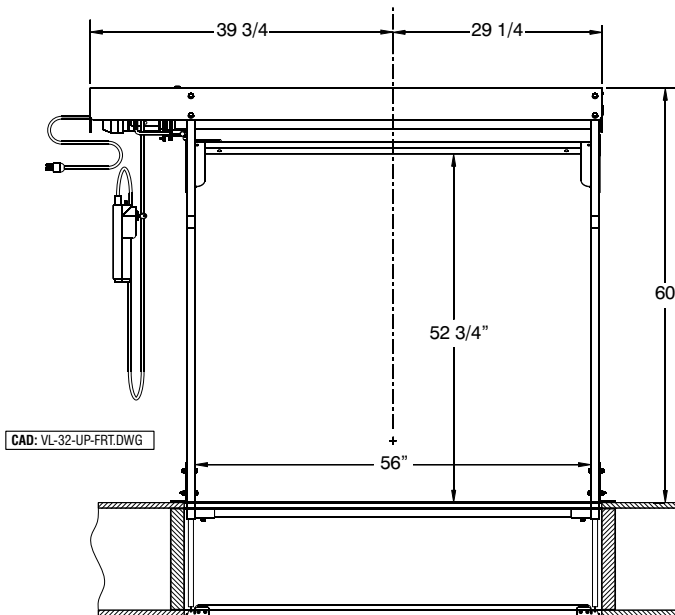
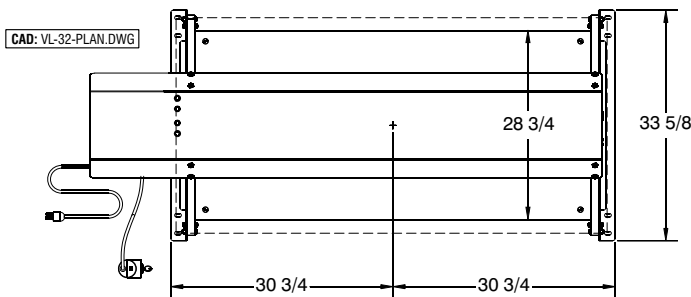

Versa Lift illustrated in the raised (UP) position.

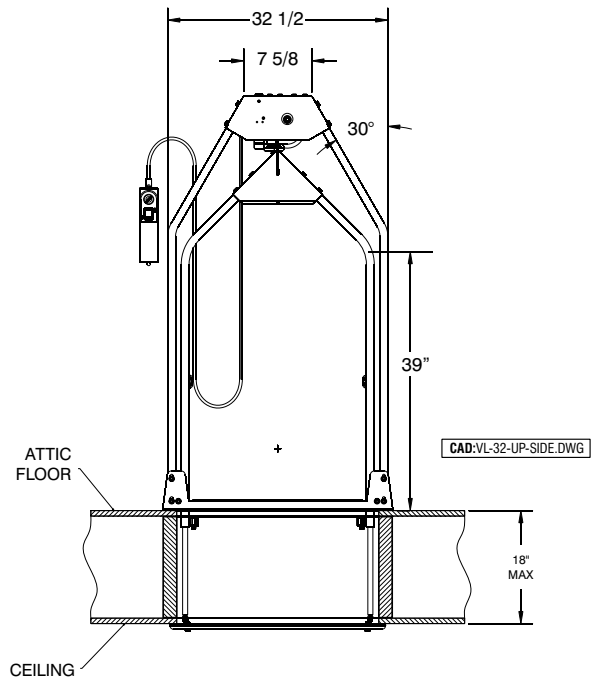

Specification Guide Cont.

Versa Lift Models 32, 32H, 32HX with 15-ft. Corded Remote Control

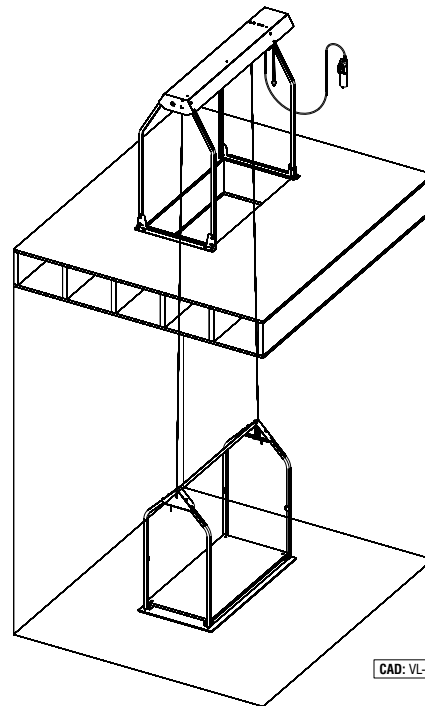
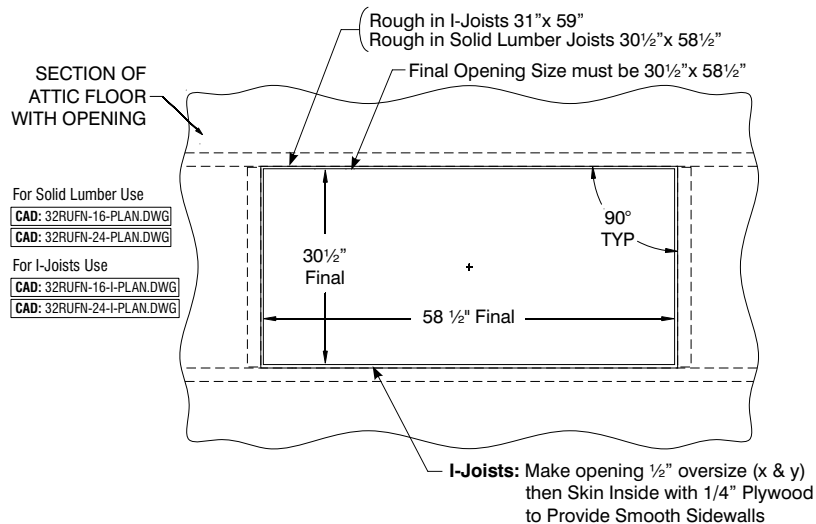

Versa Lift illustrated in the lowered (DN) position.

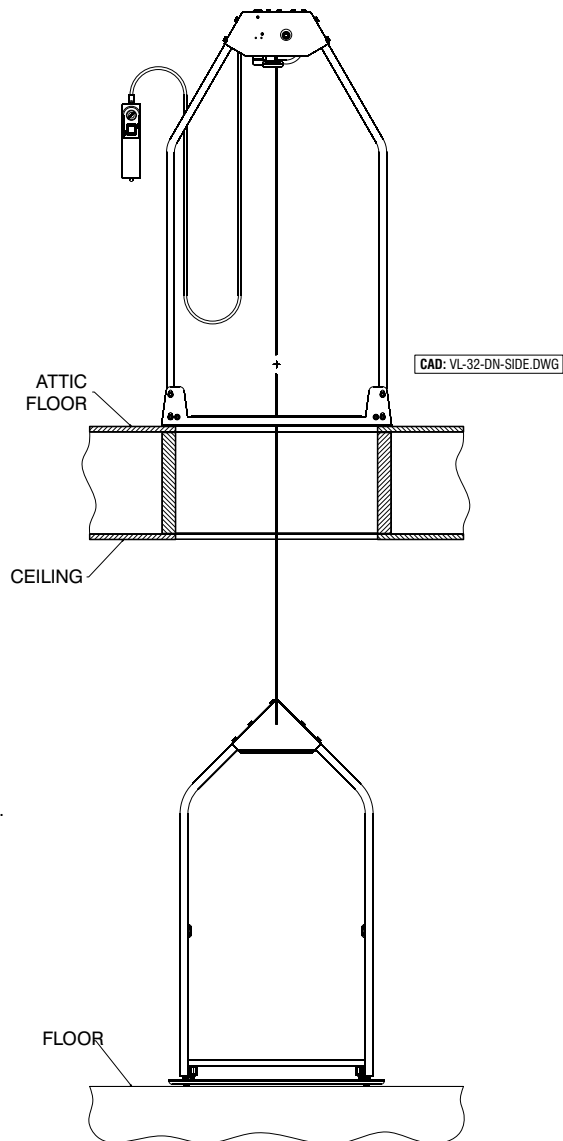
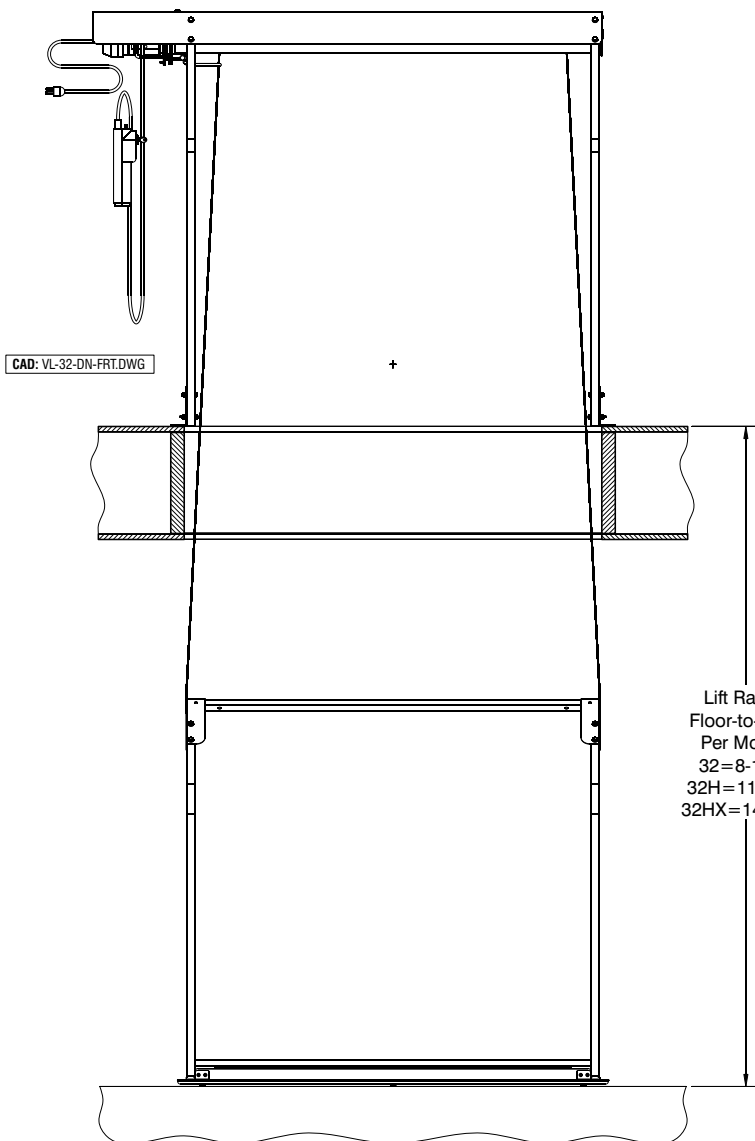

Lift Range
Floor-to-Floor
Per Model:
32=8-11-ft.
32H=11-14-ft.
32HX=14-20-ft.

Versa Lift TM

Attic Storage Lifting System

Patent Pending

Specification Guide

Versa Lift Models: 32W, 32WH, 32WHX with Wireless Remote Control

Revised 2-4-2009

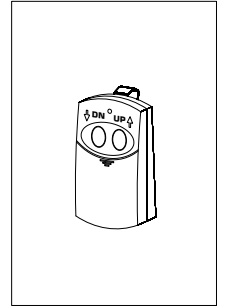

Wireless Remote

The Versa Lift electric storage lift is designed to move cargo between adjacent floors. The lift's power head mounts over an opening in the upper floor. When ascending, the lifting platform automatically stops level with the upper floor. When descending, the lifting platform automatically stops upon contacting the lower floor. The control switch operation is momentary and the motor brake is applied instantly whenever the switch is released. The platform assembly includes a spring biased door panel that automatically covers the underside of the opening whenever the platform is fully raised. This door is self-adjusting for joists up to 18" in height and can easily be sealed with common weatherstripping.

Installation Requirements:

- Opening Required:** 30 1/2 x 58 1/2" (+1/2", -0")
- Opening Finish:** Smooth perpendicular sidewalls
- Electrical:** 115 vac grounded power outlet

Installation Recommendations:

The Lift's electrical outlet and the attic lighting should preferably be on a single circuit controlled by a switch outside of the attic. The lift opening does not need to be near the ladder opening. For more detailed information about the opening requirements and for specific framing suggestions, please see the Rough-In Guide and the Versa Lift Installation Guide.

Specifications:

- Control:** Wireless hand-held remote
- Floor-to-Floor:** 32W=8-11', 32WH=11-14', 32WHX=14-20'
- Joist Height Max:** 18" (incl. decking & sheet rock)
- Lifting Capacity:** 35 Cu. Ft., 250 lbs. per load
- Platform Dimensions:** 28-3/4" x 56"
- Lift Speed:** 8"/sec. (10-ft. in approx. 15 seconds)
- Cables (2):** .093 steel w/zinc plating 1,000 lb. break
- Construction:** Powder coated steel
- Motor:** .6 HP Gear motor with automatic brake
- Voltage/Power:** 115 vac, 60 hz, 4.5 amps
- Power-head Dim.:** 34W x 69L x 60H
- Opening Required:** 30 1/2 x 58 1/2" (+1/2", -0")
- Opening Finish:** Smooth perpendicular sidewalls
- Shipping Weight:** 206 lbs.

Versa Lift illustrated in the raised (UP) position.

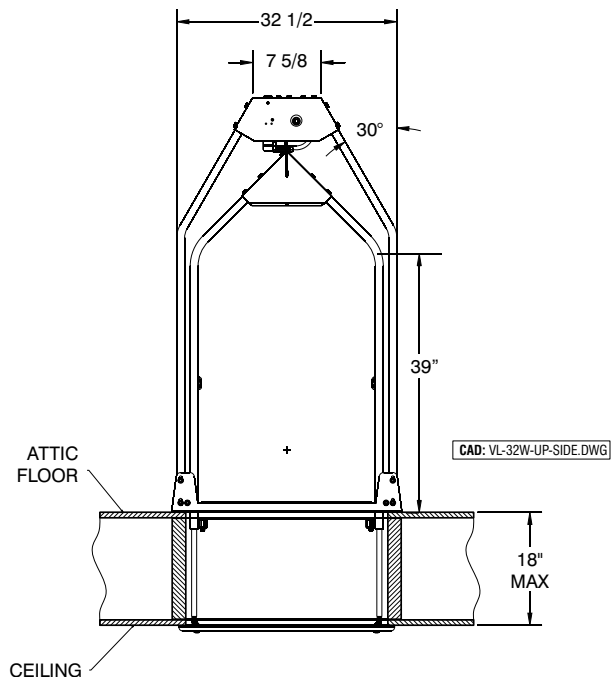
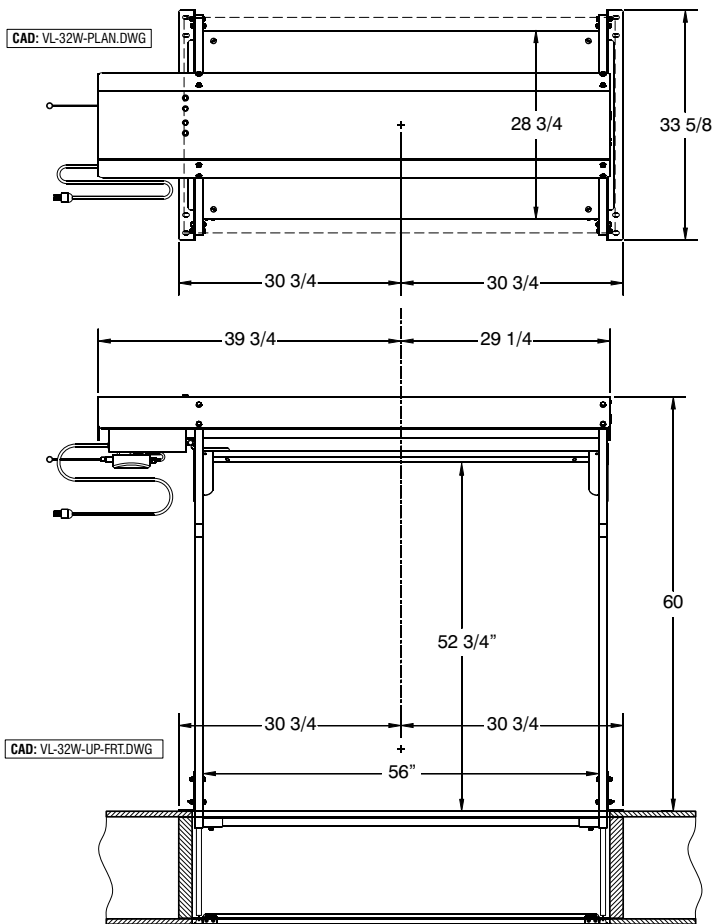

Specification Guide Cont.

Versa Lift Models: 32W, 32WH, 32WHX with Wireless Remote Control

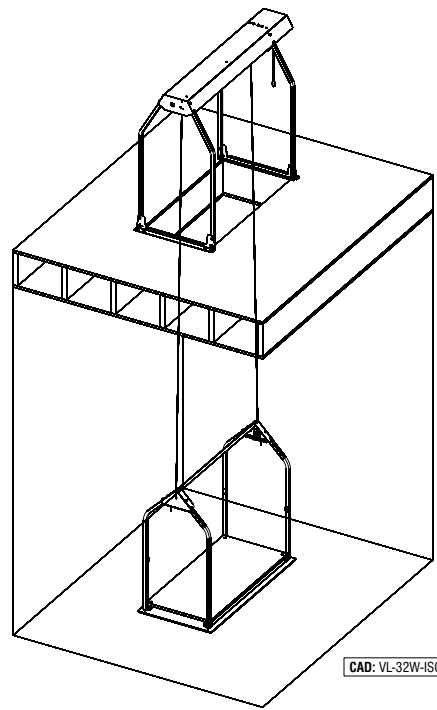
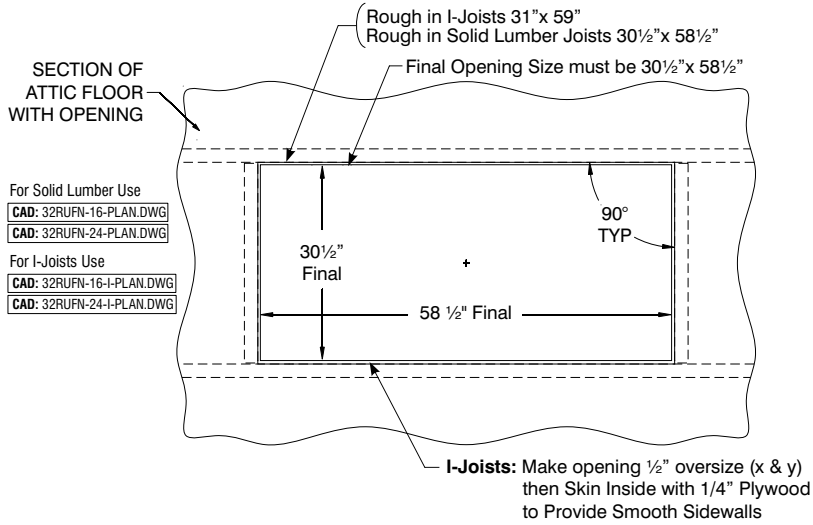

Versa Lift illustrated in the lowered (DN) position.

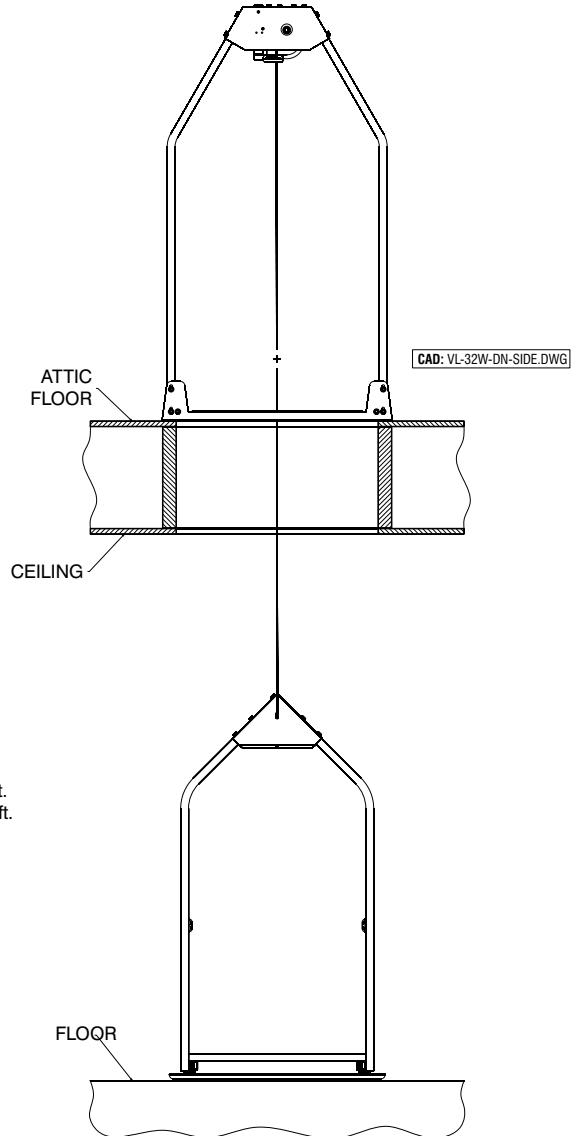
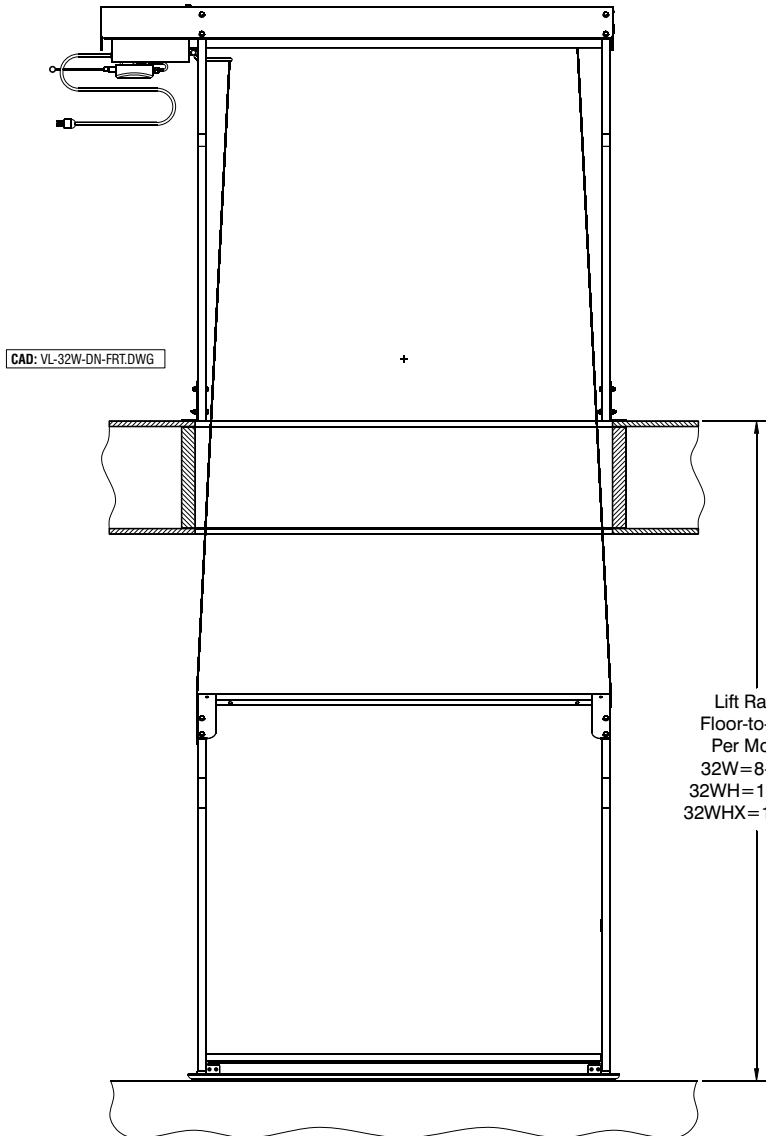

Lift Range
 Floor-to-Floor
 Per Model:
 32W=8-11-ft.
 32WH=11-14-ft.
 32WHX=14-20-ft.