

SUPER-TRAC

Portable inclined platform wheelchair lift for stairways



The Garaventa Super-Trac is the world's only portable inclined platform lift. It provides instant, affordable accessibility where stairways are a barrier. The unique platform design will accommodate all types of wheelchairs including power, child, sports and conventional adult wheelchairs. Super-Trac is ideal for public and residential buildings.

The patented Super-Trac climbs up and down stairs on steel-reinforced rubber tracks that are driven by dual, battery-powered motors. Super-Trac can climb up to 30 flights of stairs on a single charge. The large platform accommodates virtually any wheelchair. Simple, well identified controls make Super-Trac operation easy. Safety features, such as an electrically interlocked seat belt and a parking brake, ensure passenger security.

Headrest

Adjustable for passenger comfort.

Control Panel

Simple operating controls include a battery charge indicator and a key switch to prevent unauthorized use.



Seatbelt

Electrically interlocked seatbelt provides additional passenger security. Super-Trac will not operate unless seatbelt is fastened.

Battery Powered

Power is provided by 24 volt rechargeable battery pack for complete portability. Includes automatic battery charger.

Wheelchair

Tie-Down Straps

Wheelchair is securely attached to platform with 4 adjustable tie-down straps.

Auxiliary Wheels

Wheels allow easy travel across landings and between flights of stairs.

Platform

Large platform accommodates virtually any wheelchair including electric models and sports chairs.

Tracks

Rubber tracks are steel-reinforced to ensure strength and durability. The unique tread design grips all types of stair designs and materials.

Loading Ramp

An integrated loading ramp with non-skid surface makes wheelchair boarding easy.

Parking Brake

Electrically activated parking brake ensures stability during boarding.

Hydraulic Tilt

A powerful hydraulic piston tilts the wheelchair platform position for travel on the stairs.



The Garaventa Super-Trac can instantly solve your accessibility problems. It does not require any expensive and time consuming building renovations or installation permits. Super-Trac costs a fraction of a permanently installed lift or elevator. The portable design means there is no permanent impact on stair width or building egress. Super-Trac can be easily moved from one stairway to another, or even to a different building as your accessibility requirements change.



Super-Trac is simple to use. As shown in this sequence, a small operator can easily transport a passenger in a heavy power wheelchair up and down stairs. Above, the passenger has boarded the platform using the integrated ramp. The wheelchair is being secured using four adjustable tie-down straps. An electrically interlocked seat belt provides additional passenger security.

Once Super-Trac is loaded it can be easily rolled across flat surfaces, such as stair landings, using the auxiliary wheels. When not in use Super-Trac can be wheeled into a storage room. In this photo, Super-Trac has been rolled to the base of the stairway. The operator will then tilt the platform, using the hydraulic tilt control, and begin climbing the stairs.

Super-Trac climbs stairs up to a maximum angle of 35 degrees. When on the stairs, the passenger sits in a comfortable, level position. Dual electric motors will propel Super-Trac up 30 flights of stairs on a single charge. The wide track design provides excellent stability on the stairs. No exertion is required on the part of the operator who simply guides Super-Trac.

Features

- Large platform will accommodate virtually any wheelchair, including electric and sports chairs
- Integrated non-slip loading ramp
- Powerful dual motors carry up to 440 lbs (200 kgs)
- Rechargeable batteries and charger
- Operates on indoor and outdoor stairways
- Wide, double tracks securely grip stairs
- Large wheels allow easy travel across landings between stair flights
- Integrated tie-down straps and seatbelt hold wheelchair securely on platform
- Adjustable headrest
- Simple, easy to use controls
- Robust commercial design

Benefits

- Instant accessibility solution
- Economical compared to elevators and custom designed wheelchair lifts
- Requires no building renovations, no installation permits or licenses
- No permanent impact on stairway egress width
- A single unit provides access into many buildings
- Easily stored in a secure area when not in use
- Requires minimal maintenance compared to an elevator or wheelchair lift
- Great backup system for an elevator if power fails

SUPER-TRAC - Portable Inclined Platform Lift

Need Assistance?

Call your local Garaventa Lift representative today or contact us at 1-800-663-6556



The Garaventa Super-Trac can also be used outdoors to provide a portable accessibility solution for public buildings or private residences.

Specifications

- Max Capacity 440 lbs/200kgs
- Max Stair Angle 35°
- Power Sealed Batteries 24 V
- Charging Automatic 110/220 VAC
- Brake Fail-safe Electromagnetic
- Weight 253 lbs (115 kgs)
- Speed Up..... 21.4 ft (6.5 m) / min
- Speed Down..... 34.7 ft (10.6 m) / min

Wheelchair Clearances

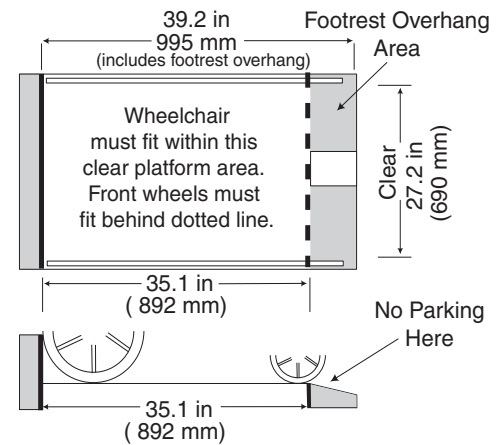

Stair Turnback Dimensions

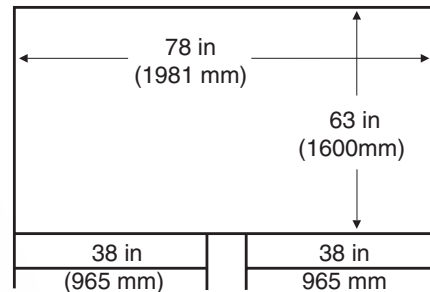

Machine Dimensions

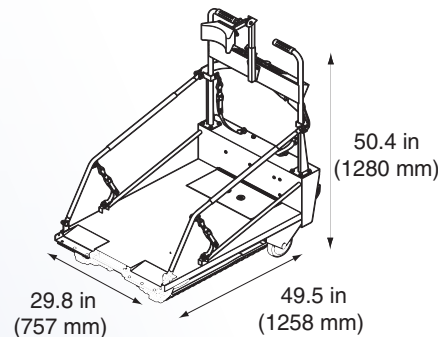

Other Garaventa Lift Products:

Garaventa Stair-Trac

Designed to transport standard, manual wheelchairs, the Stair-Trac is very compact and easy to use. Similar in design to the Super-Trac, it provides an economical way for an attendant to move a person in a wheelchair up and down stairs.

Super-Trac DVD

The Super-trac DVD gives a detailed explanation of how to properly operate the unit. To order, contact your local dealer or visit our web site.

For more information about Garaventa Lift products, visit our web site at www.garaventa.ca

Dealer Network

Garaventa's network of authorized dealers are available to assist you with product demonstrations, training and after-sales service.

Garaventa Lift

PO Box 1769,
Blaine, WA 98231-1769
7505 134A Street, Surrey, BC
Canada V3W 7B3

Phone: +1 604 594-0422
Toll Free: 1-800-663-6556
Fax: +1 604 594-9915

Email: productinfo@garaventa.ca
Web site: www.garaventa.ca
Global Portal: www.garaventalift.com

©2008 Garaventa Lift. As we are continuously improving our products, specifications outlined in this brochure are subject to change without notice.



www.garaventa.ca

Printed in Canada
15802-E-PB

Authorized Garaventa Lift Representative

