



GENESIS ENCLOSURE

PLANNING GUIDE



Please note:

Dimensions provided in this Guide are for **REFERENCE ONLY** and should not be used for site preparation or construction.

Genesis Enclosure Model Table of Contents

| | |
|--|-----------|
| What is a Vertical Platform Lift? | 4 |
| Why a Vertical Platform Lift? | 4 |
| Design Assistance | 4 |
| Finishes | 4 |
| How it Works | 5 |
| Lifting Heights and Mast Sizes | 6 |
| Leadscrew Drive System | 7 |
| Hydraulic Drive System | 8 |
| Platforms | 9 |
| Platform Configurations | 10 |
| Operating Controls | 11 |
| Optional Features | 13 |
| Garaventa Style Doors and Gates | 15 |
| Door Locks | 15 |
| Door Swings | 15 |
| Door Swing Projections | 15 |
| Base and Pit Dimensions | 16 |
| Platform Dimensions | 17 |
| Base Attachment | 18 |
| Mast Attachment | 18 |
| Leadscrew Drive System: Technical Reference | 20 |
| Hydraulic Drive System: Technical Reference | 21 |
| Loading Diagram | 22 |

What is a Vertical Platform Lift?

The Genesis Vertical Platform Lift is a cost effective way to transport a passenger in a wheelchair, or someone who has difficulty using stairs. The Genesis vertical platform lift provides a code compliant access solution for lifting heights of up to 4343mm (171") (check the regulations for your jurisdiction). With a variety of platform configurations, the Genesis is available as a 2 or 3 stop unit that can be operated independently or by an attendant. The Genesis is suitable for indoor or outdoor use and is available in a multitude of different colors and finishes so that it blends into any setting.

Why a Garaventa Genesis?

Cost-effective

A Genesis vertical lift is more cost-effective than an elevator and does not require a machine room to house the electrical and mechanical components. In applications where usage is limited to people who have difficulty using stairs, a vertical lift may be the most appropriate solution.

Blends with Environment

The Genesis vertical lift is an attractive space saving alternative to a lengthy or winding ramp. Adjacent to stairs or in an area complimentary to your building, these lifts can be finished to compliment the aesthetics of the site.

Meets ADA Requirements (USA)

Vertical platform lifts are recognized in the ADA Accessibility Guidelines and ASME A117.1 as a means to provide public building access. It complies with ASME A18.1 and CSA B355 requirements.

Design Assistance

With over 40 years of experience, Garaventa has the expertise to overcome almost any design challenge you face. Please call our Design Hot Line with your accessibility challenge.

1-800-663-6556 or +1-604-594-0422

Finishes

The standard finish is electrostatically applied and baked powder coat finish in Silver Moon for the steel panels and aluminum extrusions for the framework painted Silver Moon. As an option, these components can be painted from the large selection of RAL colors (a global paint color system). Alternatively, the Genesis enclosure can be supplied with 5mm (3/16") smoked grey or clear Plexiglas panels or 6mm (1/4") laminated glass panels (supplied by others).

Outdoor Applications

When located outdoors, an outdoor package, which includes treatments for extreme conditions, is included to enhance durability and reliability. Included in the base outdoor package are: hot dipped galvanized base, primed mezzanine brackets, sealed electrical box, rubber boots on switches and stainless steel fasteners. Additional protection may be required in extreme environments. A tall enclosure with a roof is strongly recommended for all outdoor applications.

How it Works

The Genesis vertical lift is offered in a variety of configurations and styles for different accessibility challenges. All versions of the Genesis vertical lift operate in the same manner and consists of a complete drive system, a platform with side walls, doors with an interlock system and call stations.

The mast houses the electrical and mechanical components that raise and lower the cantilevered

platform. The doors or gates cannot be opened unless the platform is at an appropriate landing. The platform is called to the landing by using the call stations located at each landing. Once at a landing, the door interlock is released and the door can be opened.

The Genesis vertical lift can be used to provide accessibility either indoors or outdoors and can be installed directly on the floor or in a 76mm (3") deep pit.

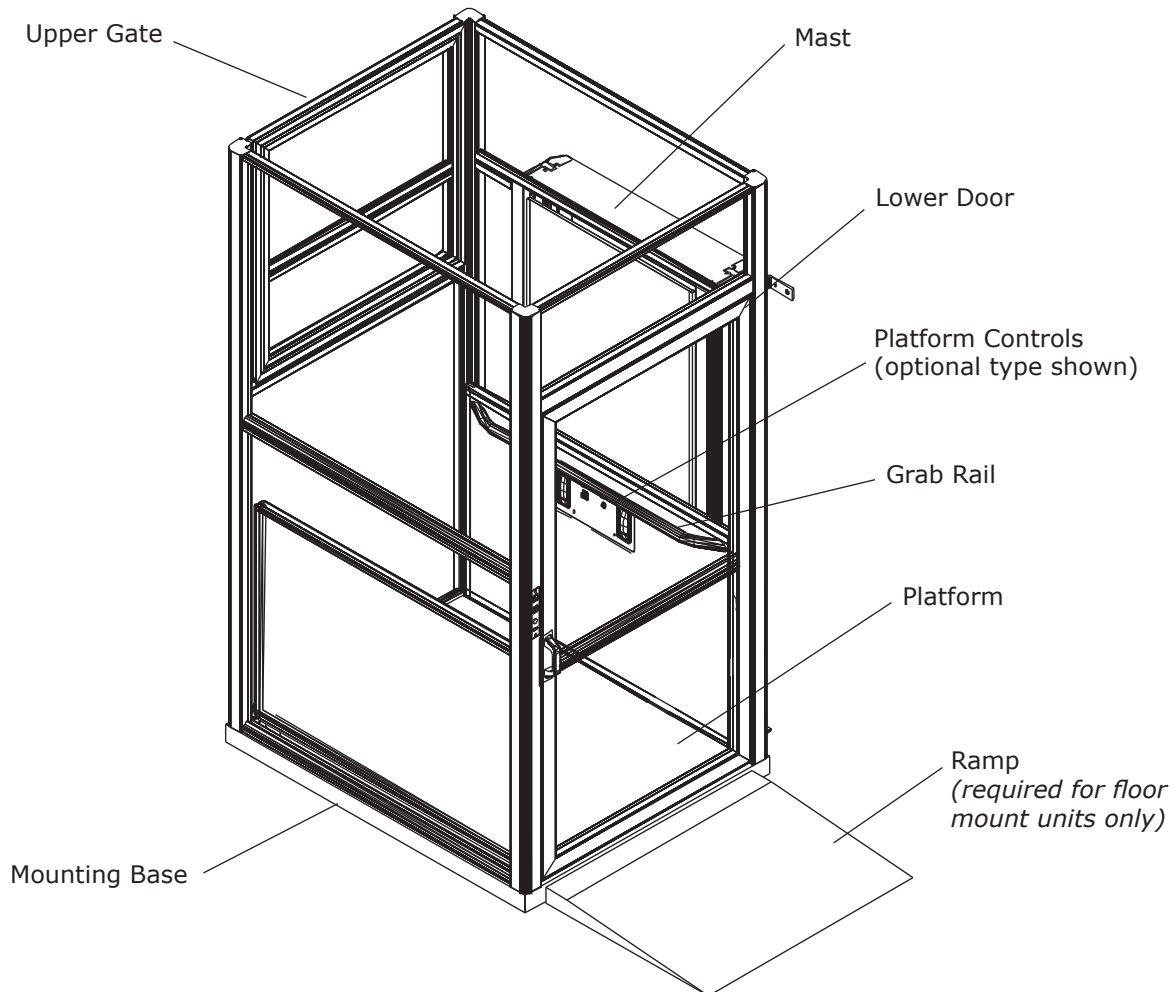

Enclosure Model with Standard Straight-Through Configuration

Lifting Heights and Mast Sizes

The mast size required for a particular site is determined by the vertical travel required between the upper and lower landings. When the site is measured, **the lift height "H" is always defined as the distance from the lower landing (bottom of pit or floor) where the lift will sit to the upper landing floor** as shown in the diagram below. An accurate measurement of

the "H" dimension is crucial for your custom designed lift. Be certain the height you provide is accurate. We strongly recommend using the "as built" dimension.

The width of the mast is 998mm (39 1/4") for all mast heights.

Based on the measured value of "H" the drive mast is selected as follows:

| Mast Size | Max. "H" Value | Mast Structure Height | Mast Tieback Height |
|-------------------|----------------|-----------------------|---------------------|
| GVL - 42 | 1168mm (46") | 1737mm (68.4") | 1643mm (64.7") |
| GVL - 60 | 1626mm (64") | 2194mm (86.4") | 2101mm (82.7") |
| GVL - 72 | 1930mm (76") | 2498mm (98.3") | 2405mm (94.7") |
| GVL - 96 | 2540mm (100") | 3108mm (122.4") | 3015mm (118.7") |
| GVL - 120 | 3150mm (124") | 3718mm (146.4") | 3625mm (142.7") |
| GVL - 144 | 3759mm (148") | 4327mm (170.4") | 4234mm (166.7") |
| GVL - 168* | 4369mm (172")* | 4937mm (194.4")* | 4844mm (190.7") |

Note: GVL - 96, GVL - 120, GVL - 144 and GVL - 168 are available as Hydraulic drive only.

*Hydraulic drive with split (2 pce) mast standard.

Two stop lift in a pit and floor mount application. An optional three stop unit is also available.

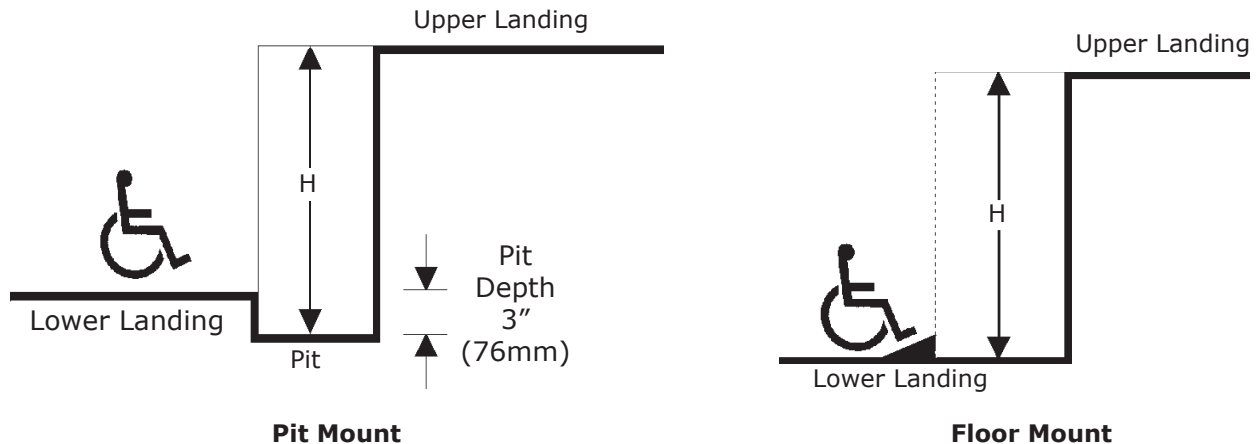

Leadscrew Drive System

Single-phase 2 HP motor attached to a 1" ACME screw, the platform travels at 3 meters (10 ft.) per minute.

Note: GVL - 42, GVL - 60, GVL -72 lifting heights only.

Mains Power Requirement:

North America

120 VAC single phase on a dedicated 20 amp circuit.

International

208 - 240 VAC single phase on a dedicated 16 amp circuit.

Electrical Disconnect (optional)

An electrical disconnect can be supplied with the lift for both safety reasons and customer convenience. This disconnect shuts off the mains power and the 24V battery lowering system to the lift. For the Enclosure Model, the disconnect is located on the side of the mast closest to the lower landing door. For the Shaftway Model, the disconnect is located on the outside of the shaftway walls in a location determined by local code requirements.

Manual Lowering Handwheel (Lead Screw Model Only - standard)

The manual lowering handwheel has a black plastic handle and slotted shaft that engages a crosspin on the main drive screw.

Battery Powered Emergency Lowering (Lead Screw Model Only - optional)

The Genesis Leadscrew Model can be supplied with an optional battery-powered emergency lowering system which is automatically activated in the event of a power failure. Using the down directional control, the battery powered emergency lowering system lowers the platform at a speed of approximately 0.3m/min. (1 ft/min.).

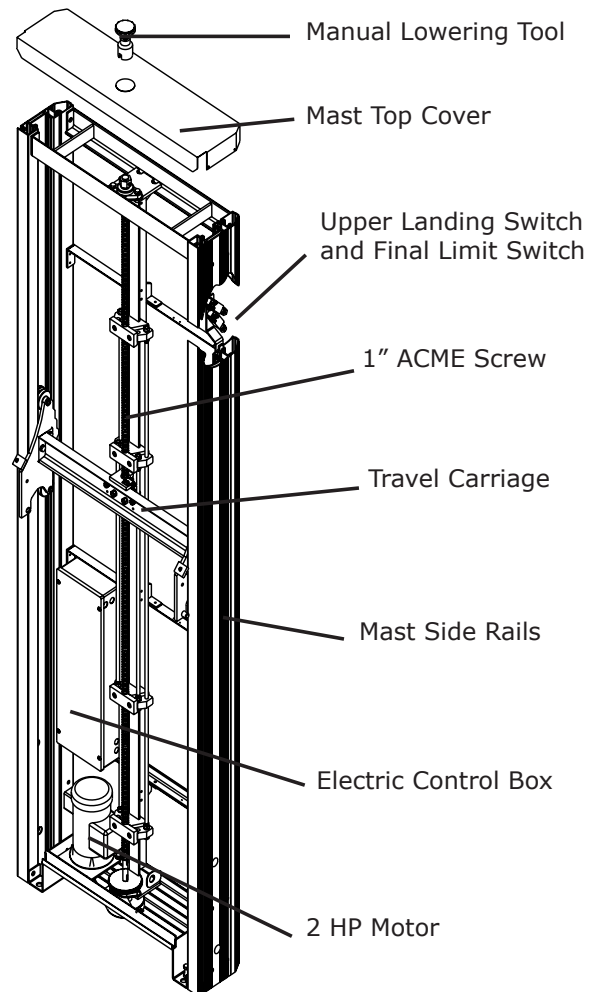

Hydraulic Drive System

Single-phase (2.2 KW), 24VDC hydraulic motor. Continuous mains power and auxiliary power system. The lift connects directly to the building power. The power is reduced to 24 VC to operate the control system and drive the motor. The lift is equipped with an auxiliary power system that enables the lift to operate if mains power is lost. The platform travels between landings at 5.2 meters (17ft.) per minute. ***Required for heavy use lifts or lifts equipped with a Fan and Ventilation System.**

Mains Power Requirement:

North America - 120 VAC single phase on a dedicated 15 amp circuit.

International - 208 - 240 VAC single phase on a dedicated 16 amp circuit.

Full Time Battery Operation (optional)

For very low use applications and basic units, full time battery operation is appropriate.

Electrical Disconnect (optional)

An electrical disconnect is supplied with the lift for both safety reasons and customer convenience. This disconnect shuts off the mains power and the 24V battery back-up system to the lift.

The Enclosure Model disconnect is on the side of the mast closest to the lower landing door.

Manual Lowering

(Hydraulic Model Only - standard)

The manual emergency lowering device consists of a pull knob mounted in a box on the side of the mast. When used, the platform is gently lowered to the landing.

Split Mast (Hydraulic Drive Only - optional)

For installation sites where it would be difficult to place the drive mast into position as a single piece, the split mast option is available for GVL-120 and GVL-144. GVL-168 Hydraulic Models are supplied standard with a split mast.

Raised Pump and Control Box (Hydraulic Drive Only - optional)

This option is ideal for locations that are subject to flooding. The pump and electrical controls are re-located higher (exact location depends upon mast

size). Available for 96" mast heights and taller.

Remote Drive Cabinet (Hydraulic Drive Only - optional)

For the ultimate in quiet operation, the drive system can be located up to 3 meters (10 feet) away in a remote drive cabinet.

Mast Heater (Hydraulic Drive Only - optional)

For outside installations where cold temperatures are a concern, a mast heater can be installed to protect hydraulic fluid from freezing.

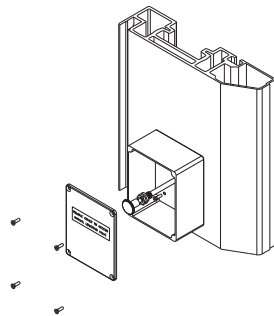
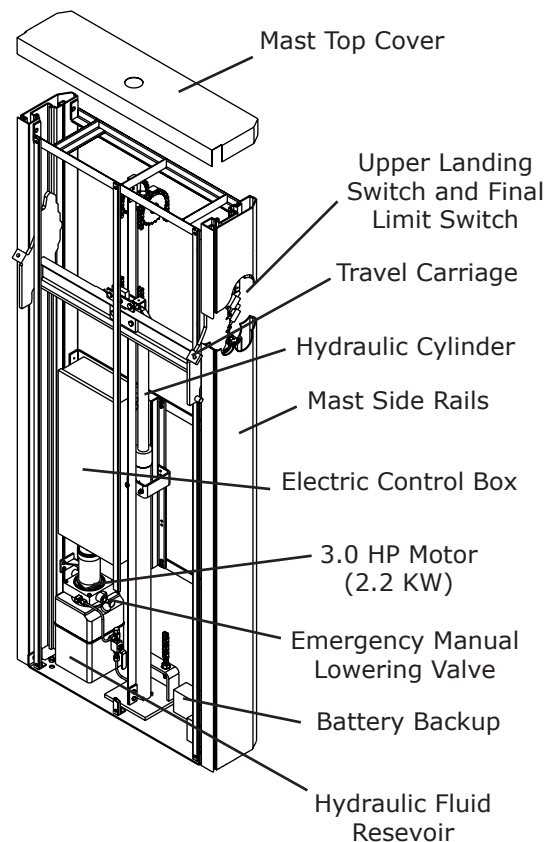

Platforms

The platform is rated for a capacity of 340 kg. (750 lbs.) and has 1100 mm (43") high side walls. The side wall in front of the mast includes a grab rail and platform controls.

Standard sizes are typically code-compliant for straight through commercial applications. Larger sizes may be required for other on/off configurations or to facilitate ease of use.

Enclosure Platforms

The Genesis Enclosure Model has 3 standard platform sizes to meet your requirements:

- Standard
- Mid-Size
- Large

Exact platform dimensions will vary depending upon the model and configuration. For Enclosure Model platform dimensions, see page 17.

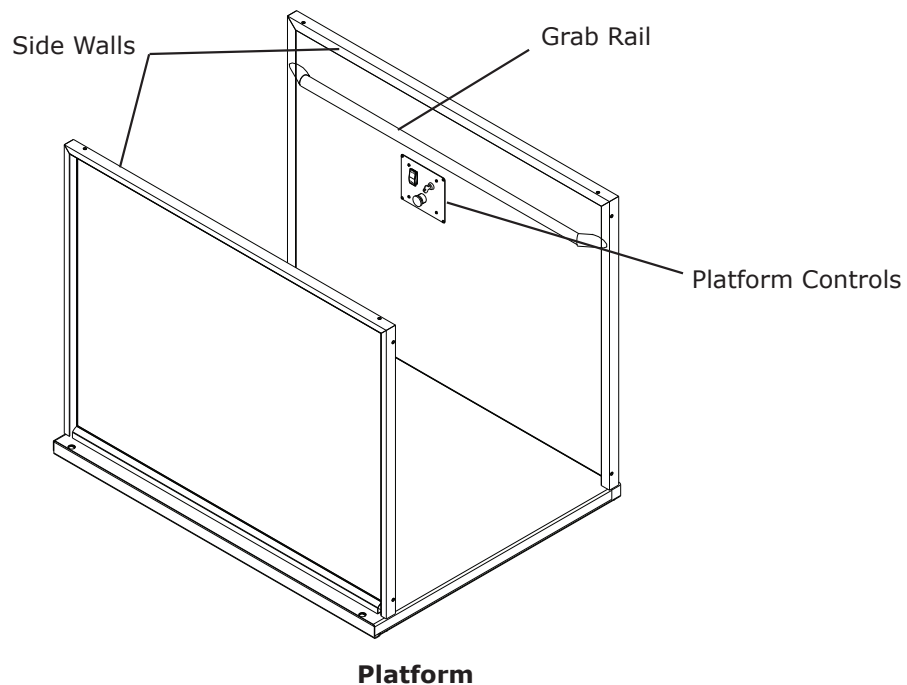

Platform Configurations

Entry/Exit Configurations

The Genesis is available with a straight through (180°), a 90° or an on/off same side (360°) platform configuration.

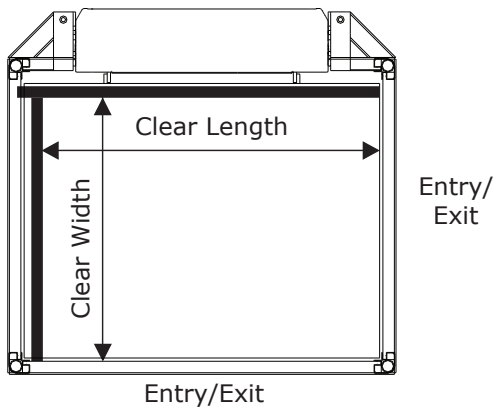

90° Configuration

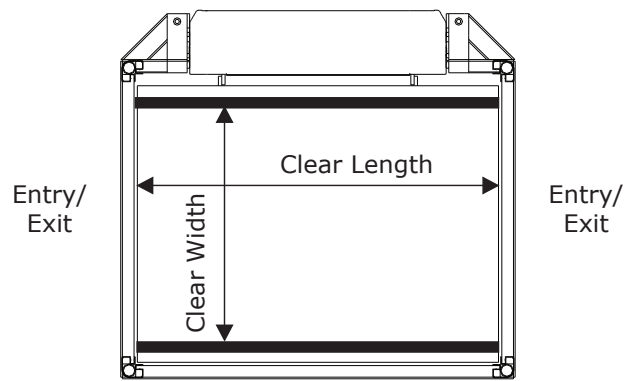

Straight Through (180°) Configuration

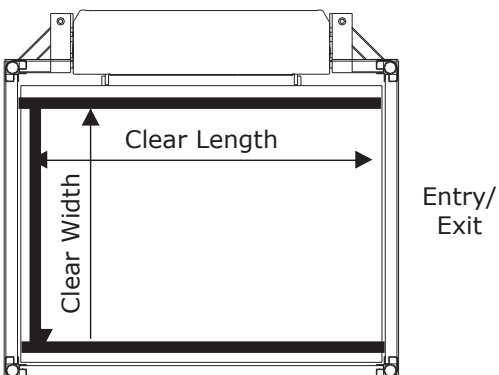

On/Off Same Side (360°) Configuration
(must have a lift height of 2253mm (88 3/4")
or greater)

Operating Controls

Rocker Style Switches (standard)

The Genesis vertical lift comes with standard rugged indoor/outdoor constant pressure switches, rated to IP 67. The platform control panel has an illuminated audible emergency stop switch. All controls can be fitted with an optional AEMA key switch.

Push Button Control Package (optional upgrade)

This features illuminated and tactile constant pressure directional control switches. Directional controls also feature braille symbols.

Platform Courtesy Lighting in Rocker and Push Button Packages

Platform courtesy lighting is included in both the rocker and push button packages. The light remains ON for the duration of platform travel and for 10 seconds after the platform arrives at the landing.

Keyed Call Station and Platform Controls (optional)

Prevents the unauthorized use of the lift. Call stations and platform controls can be set up for keyed operation.

Shaftway Frame Mounted Call Stations: Fire Rated Doors

When a fire rated door is used the call stations are usually mounted in the steel frame of the door, similar to the Garaventa style door call stations. Wall mount call stations are available as an option.

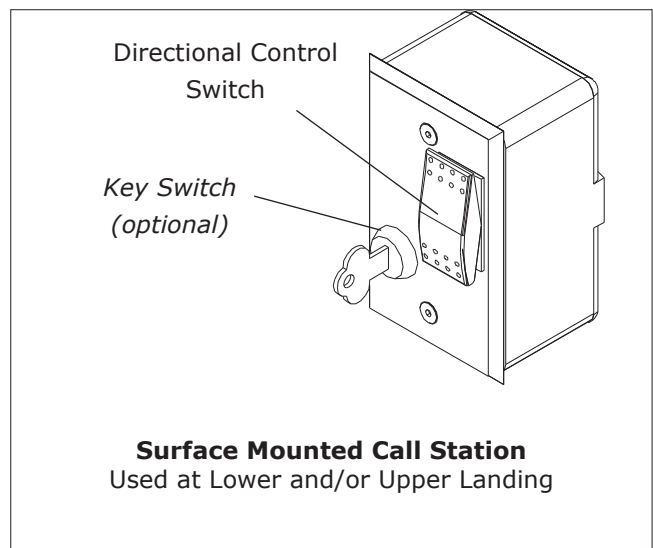
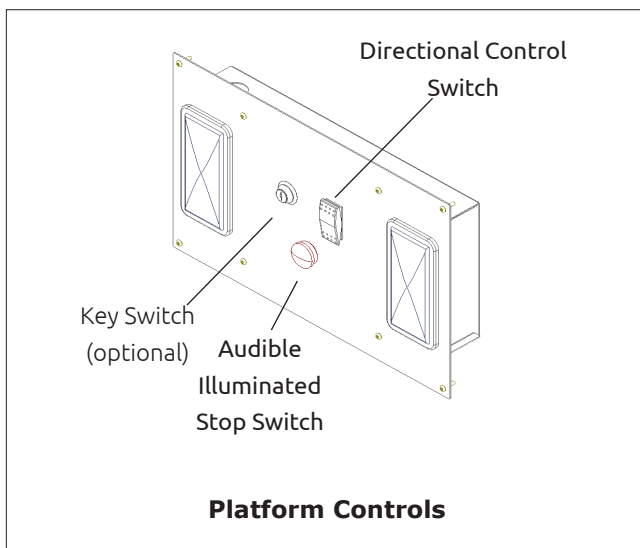
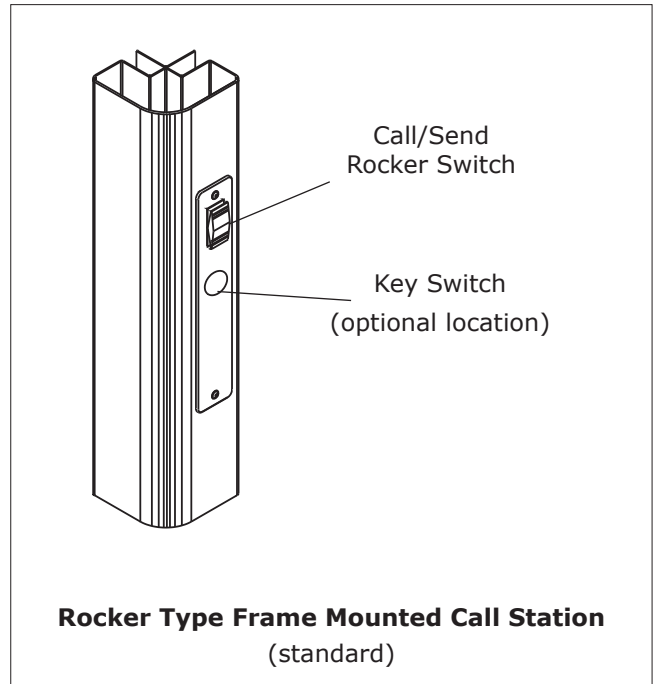

Operating Controls (Continued)

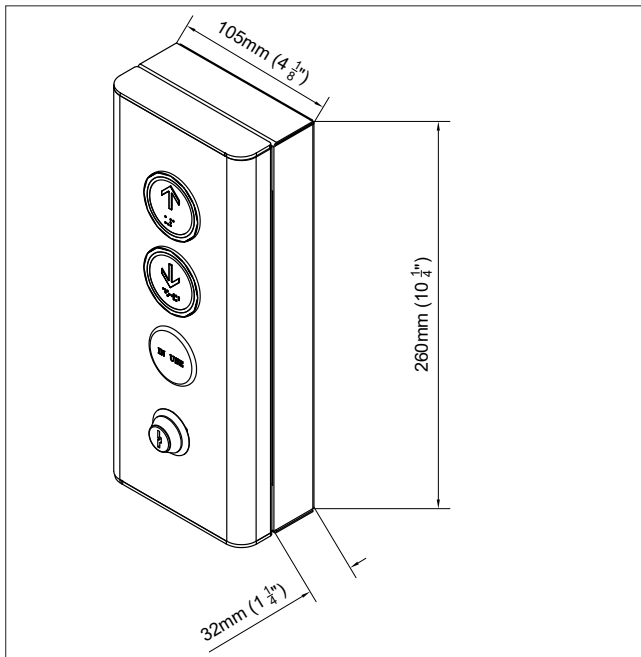
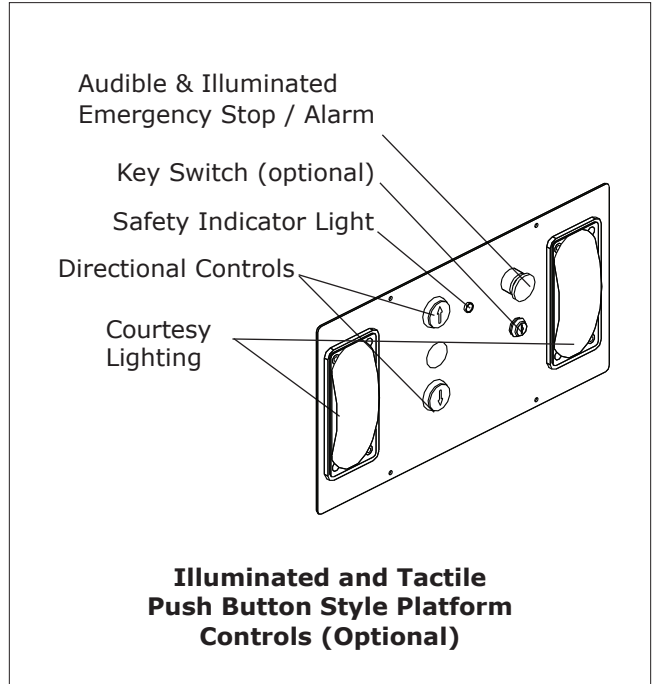
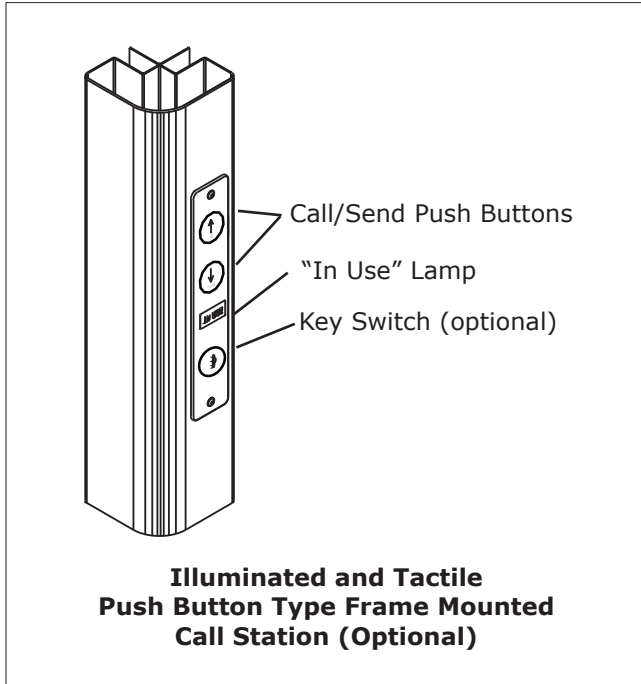

**Push Button Style
 Surface Mounted Call Station**

Surface Mount Call Station Dimension
 260mm (10 1/4") x 105mm (4 1/8") x 32mm (1 1/4")
 For dimensional purposes. Not exactly as shown.

Optional Features

Autodial Telephone

In locations where the lift cannot be easily monitored and as required by code in certain jurisdictions, an autodial telephone can be installed on the platform. The Autodial telephone allows the lift user to make contact with pre-programmed help numbers with the push of a button.

Plexiglas Dome (optional)

For outdoor applications, a bronze tinted Plexiglas dome is recommended. It is fastened to the top of the enclosure. This dome comes standard with a drip rail for rain and condensation.

Sloped Roof

For directional water run off or for installations where a dome would not be appropriate (i.e. against a building), the lift can be equipped with a sloped steel roof.

Fan and Ventilation System (optional) (with Dome or Sloped Roof Only)*

The fan and ventilation system consists of two exhaust fans, a thermostatic control and a 12 VDC battery backup. The dual fans circulate and

completely replace the air in the enclosure every minute when the inside enclosure temperature exceeds 85°F. The Fan and Ventilation System is in accordance with ASME A18.1 code requirements.
*Requires Continuous Mains Power.

Note: Codes require a fan and ventilation system for an enclosure lift exposed to direct sunlight fitted with Plexiglas panels and a solid roof.

Garaventa PDO - Power Door Operator

The Garaventa Power Door Operator (PDO) enables automatic door opening and closing. The Garaventa PDO is clutched and obstruction sensing. It is suitable for use on Garaventa aluminum framed 36", 42", and 44" doors and gates.

Arrival Gong and Digital Floor Display

The platform mounted arrival Gong and Digital Floor Display provide audio and visual platform location information.

Ramps (optional)

A ramp is used when a pit is not provided. The ramps are available in slopes of 1:10 and 1:12. Both slopes are available in widths of 1069mm (42"), 1225mm (48 1/4") or 1375mm (54 1/8"). It is recommended that you use a Power Door Operator and a wall mount call station at landings where a ramp is used. Contact your local authorized Garaventa Lift representative to confirm the local code requirements associated with using a ramp.

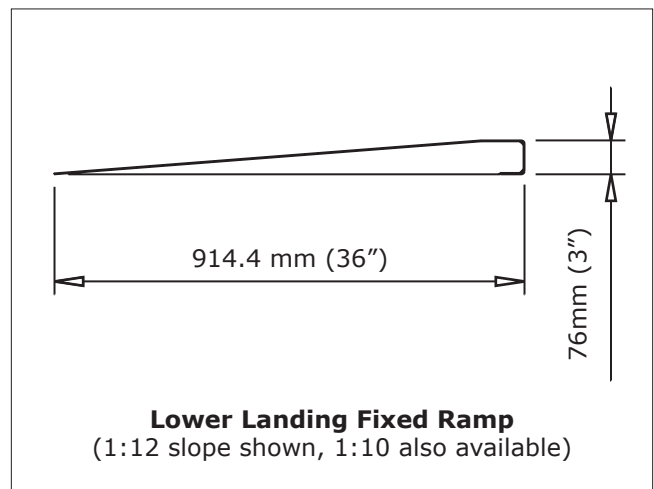
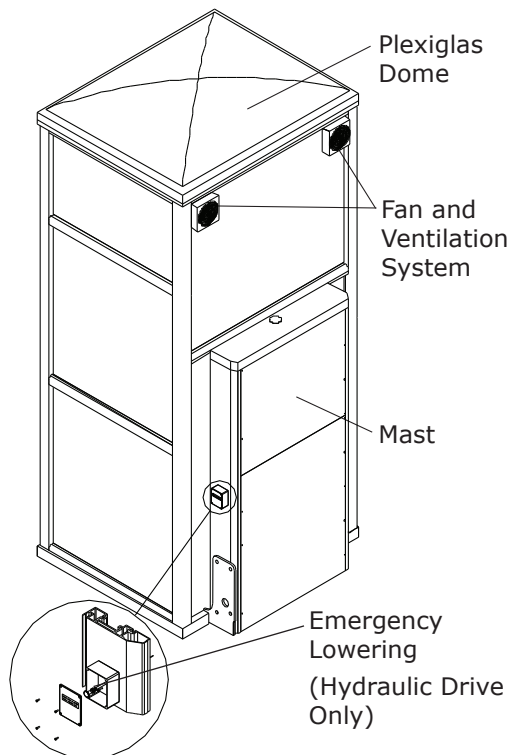

Optional Features (Continued)

Infill Panel Kits (Optional)

Custom infill panel kits finish the open space between the enclosure corner post and the building wall, next to the mast.

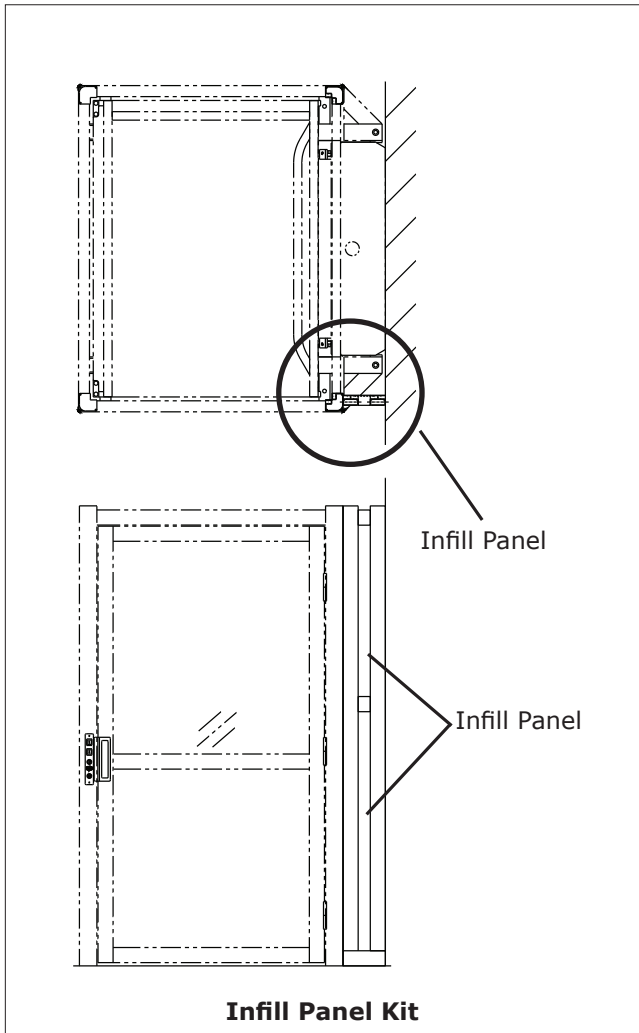

Bridges (optional)

A custom bridge can be supplied for situations where a space must be crossed in order to use the lift. Please contact your Garaventa Lift representative to discuss these custom fabricated bridges and barrier options.

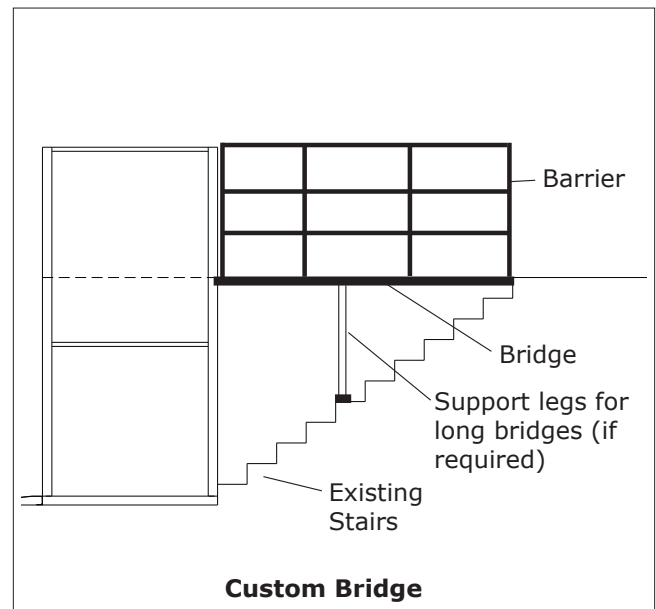

Garaventa Style Doors & Gates

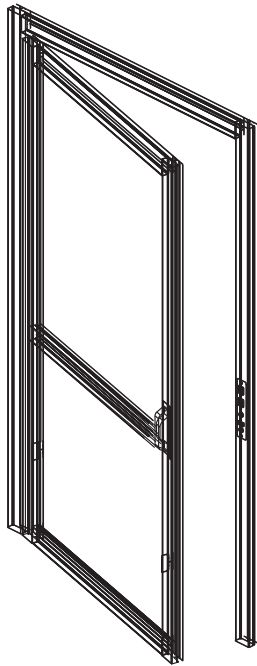

The Enclosure model utilizes Garaventa style doors and/or gates. These non-fire rated doors and gates are prehung in a extruded aluminum frame powder coat Silver Moon. The doors and gates are constructed of matching aluminum extrusions with a powder coated 16 gauge galvanized steel kickplate and an upper panel (powder coated 16 gauge galvanized steel, bronze or clear Plexiglas, or laminated glass). Garaventa doors are equipped with an offset "D" handle. Custom finishes are also available as an option, please refer to page 4.

The door height is 2032mm (80") and the gate height is 1070mm (42 1/8") and are both available in 3 widths:

- 905mm (35 5/8")
- 1046mm (41 1/8")
- 1109mm (43 5/8") (for wide side 90° configurations)

Door Locks

WR500 (CSA certified)

The WR500 is the standard locking system used across all Genesis Enclosure units. This 24 VDC interlock is integrated with the safety circuit to verify that the Garaventa door or gate is securely locked whenever the platform is not at the landing. Known for its reliable performance and ease of installation, the WR500 meets all relevant safety and performance

standards, making it a dependable choice for consistent and efficient operation.

Locks by Others

Garaventa lifts can be configured to accept interlocks or strikes by others, typically found in fire doors. Consult your local Garaventa representative for more information.

Door Swings

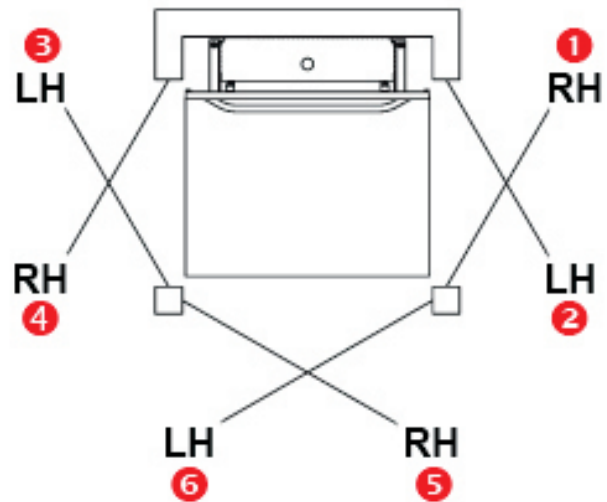

Gate Positions & Swing Options

Door Swing Projections

| Door Width | Projection |
|------------|-------------------|
| 36" | 39 1/4" (998 mm) |
| 42" | 44 7/8" (1139 mm) |
| 44" | 46 3/8" (1178 mm) |

Base and Pit Dimensions

(For Leadscrew or Hydraulic Drive System)

| Platform Size | Base Width | Base Length | Pit Width | Pit Length |
|-----------------|------------------|------------------|------------------|------------------|
| Standard | 1399mm (55 1/8") | 1505mm (59 1/4") | 1427mm (56 1/8") | 1530mm (60 1/4") |
| Mid-Size | 1399mm (55 1/8") | 1656mm (65 1/8") | 1427mm (56 1/8") | 1681mm (66 1/8") |
| *42 x 60 | (Table below) | (Table below) | (Table below) | (Table below) |
| Large | 1551mm (61 1/8") | 1656mm (65 1/8") | 1579mm (62 1/8") | 1681mm (66 1/8") |

| Configuration | Platform Size | Base Width | Base Length | Pit Width | Pit Length |
|---|----------------|------------------|------------------|------------------|------------------|
| Straight through 180° Entry/Exit | 42 x 60 | 1522mm (59 7/8") | 1660mm (65 7/8") | 1548mm (60 7/8") | 1685mm (66 3/8") |
| 90° Entry/Exit | 42 x 60 | 1522mm (59 7/8") | 1734mm (68 1/4") | 1548mm (60 7/8") | 1758mm (69 1/4") |
| 360° On/Off Same Side Entry/Exit Adjacent to Mast | 42 x 60 | 1452mm (57 1/8") | 1734mm (68 1/4") | 1477mm (58 1/8") | 1758mm (69 1/4") |
| 360° On/Off Same Side Entry/Exit Opposite to Mast | 42 x 60 | 1452mm (57 1/8") | 1808mm (71 1/8") | 1477mm (58 1/8") | 1833mm (72 1/8") |

Enclosure Base and Pit Dimensions

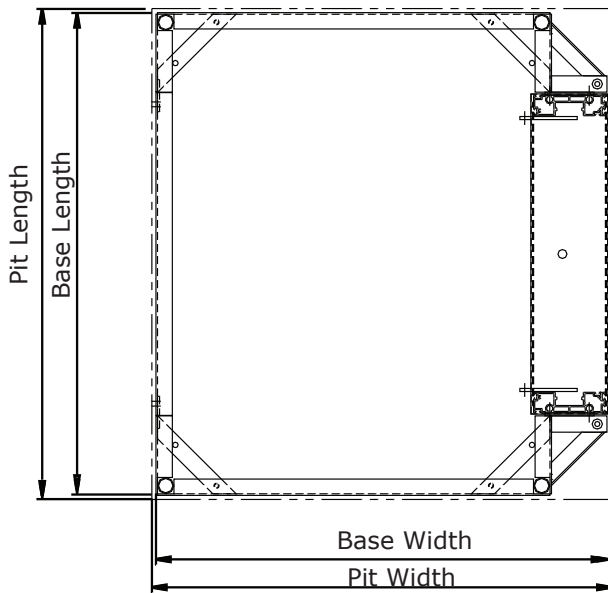

*42 x 60 base/pit dimensions are for the A 18.1 maximum allowable clear platform space.

- Add 38mm (1 1/2") to pit width if a mast tie-back rail is used.

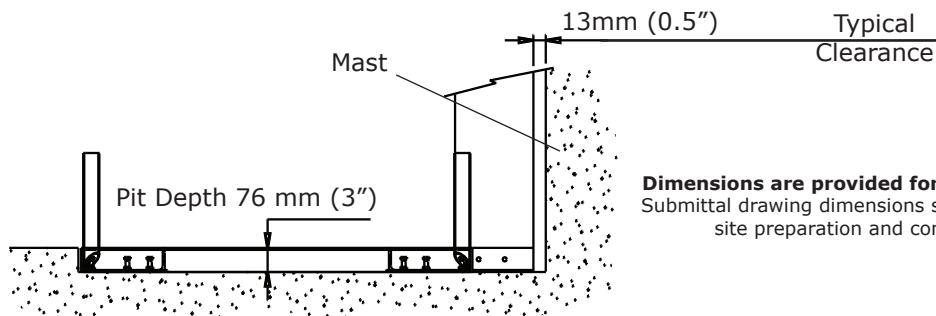

Dimensions are provided for reference only.
Submittal drawing dimensions should be used for site preparation and construction.

Platform Dimensions

| Configuration | Platform Size | Platform Clear Width | Platform Clear Length | Net Usable Area |
|--|---------------|----------------------|-----------------------|----------------------------|
| Straight through 180° Entry/Exit | Standard | 947mm (37 1/4") | 1370mm (53 7/8") | 1.30sq. m. (13.95 sq. ft.) |
| | Mid-Size | 947mm (37 1/4") | 1520mm (59 7/8") | 1.44sq. m. (15.50 sq. ft.) |
| | *42 x60 | 1067mm (42") | 1524mm (60") | 1.63sq. m. (17.50 sq.ft.) |
| | **Large | 1099mm (43 1/4") | 1520mm (59 7/8") | 1.67sq. m. (17.98 sq. ft.) |
| 90° Entry/Exit | Standard | 1017mm (40") | 1295mm (51") | 1.32sq. m. (14.17 sq. ft.) |
| | Mid-Size | 1017mm (40") | 1446mm (56 7/8") | 1.47sq. m. (15.83 sq. ft.) |
| | 42 x60 | 1067mm (42") | 1524mm (60") | 1.63sq. m. (17.50 sq.ft.) |
| | Large | 1168mm (46") | 1446mm (56 7/8") | 1.68sq. m. (18.17 sq. ft.) |
| 360° On/Off Same Side Entry/Exit Adjacent to Mast | Standard | 947mm (37 1/4") | 1295mm (51") | 1.22sq. m. (13.20 sq. ft.) |
| | Mid-Size | 947mm (37 1/4") | 1446mm (56 7/8") | 1.37sq. m. (14.74 sq. ft.) |
| | 42 x60 | 1067mm (42") | 1524mm (60") | 1.63sq. m. (17.50 sq.ft.) |
| | Large | 1099mm (43 1/4") | 1446mm (56 7/8") | 1.58sq. m. (17.11 sq. ft.) |
| 360° On/Off Same Side Entry/Exit Opposite to Mast | Standard | 1017mm (40") | 1220mm (48") | 1.24sq. m. (13.36 sq. ft.) |
| | Mid-Size | 1017mm (40") | 1372mm (54") | 1.40sq. m. (15.02 sq. ft.) |
| | 42 x60 | 1067mm (42") | 1524mm (60") | 1.63sq. m. (17.50 sq.ft.) |
| | Large | 1169mm (46") | 1372mm (54") | 1.60sq. m. (17.27 sq. ft.) |

* 42 x 60 meets A. 18.1 requirements for maximum allowable clear platform space at 750lbs.

** Large exceeds A 18.1 maximum allowable clear platform space at 750 lbs.

Base Attachment

All Genesis lift bases are fastened to the floor/pit at the lower landing. It is recommended that the floor is a level concrete surface rated for 3500 PSI with a minimum thickness of 102mm (4"). If the floor surface does not meet these specifications, it must be able to withstand the loads shown on the loading diagram.

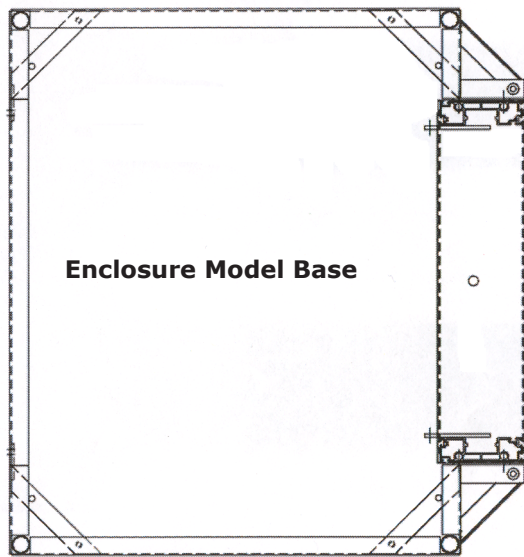

Mast Attachment

All Genesis masts must be fastened to structural support. The Genesis is supplied with adjustable tie back brackets. These brackets are fastened to the mast and installed into a load bearing support wall. This helps to stabilize the mast. Refer to the loading diagram for the loads that must be supported by the wall. Consult with a local professional engineer to determine structural suitability.

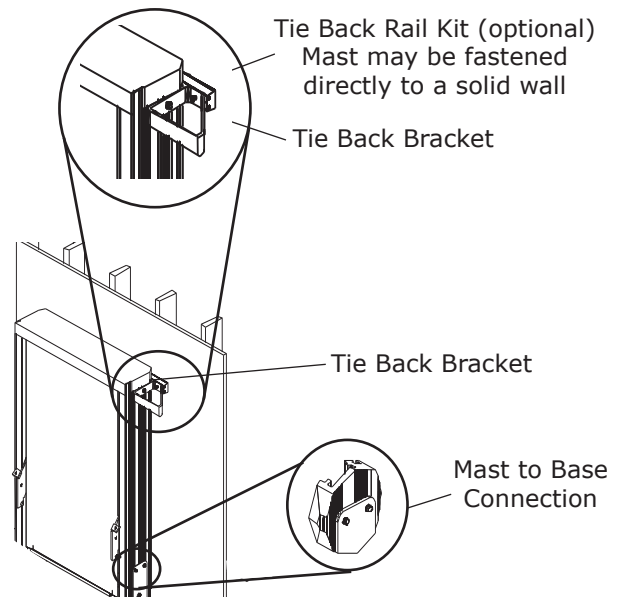

Mast Attachment Details

Mast Attachments (Continued)

Mast Attachment Methods Y Brace and U Brace

When the adjustable mast tie back bracket cannot be used, mast stabilization can be achieved with the installation of a tie back bracket.

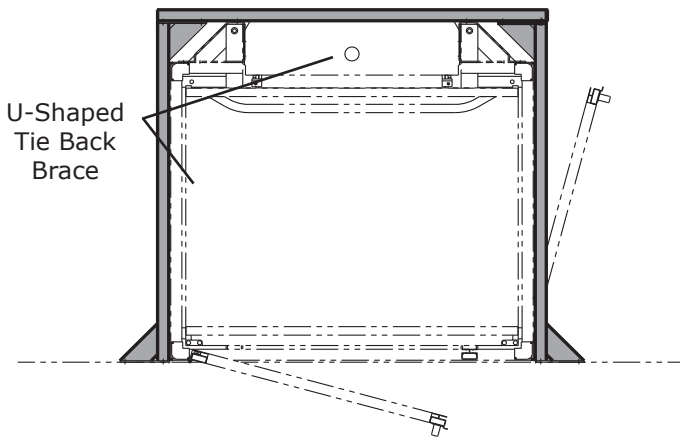

U-Shaped Tie Back Brace (Optional)

The U Brace wraps around the enclosure lift and is fastened to structural member at the upper landing.

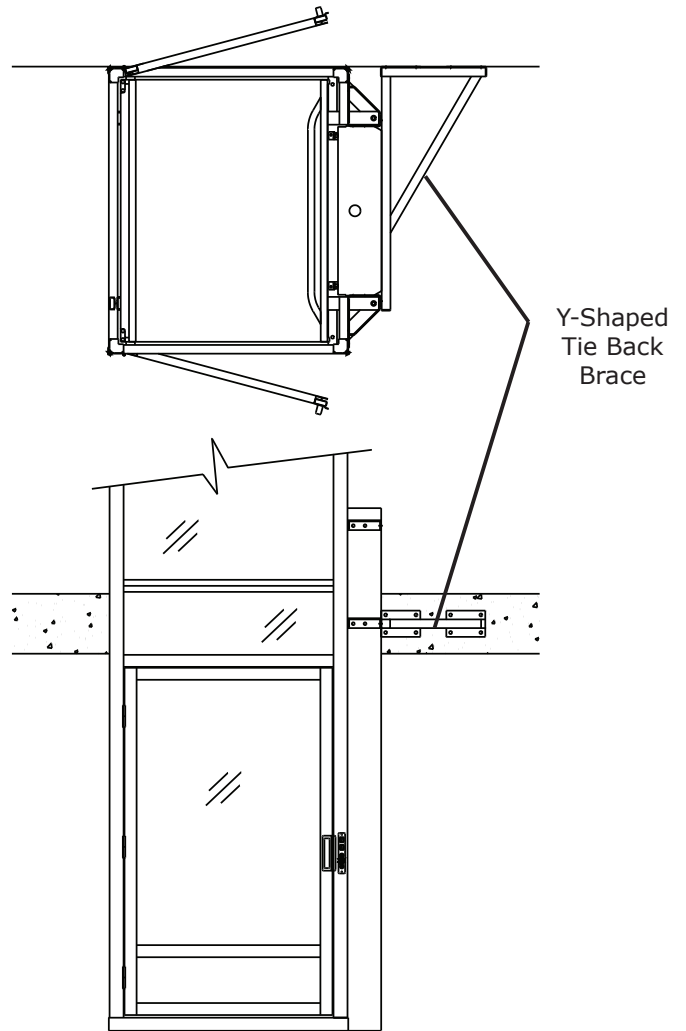

Y-Shaped Tie-Back Brace (Optional)

Attached to the mast, the Y Brace forms a triangle of support when it is fastened to a structural member at the upper landing.

Lead Screw Drive System: Technical Reference

Platform Sizes:

- Standard
- Mid-size
- Large

For clear platform dimensions, please see page 18.

Rated Load:

340 kg (750 lbs), with a safety factor of 5

Drive System:

Mains Power:

120 VAC single phase on a dedicated 20 amp circuit. Outside N.A. 208-240 VAC single phase on a dedicated 16 amp circuit.

Drive Type: ACME screw (1" diameter)

Motor: 2 HP, AC Motor. Variable frequency control for smooth start and stop.

Daily Cycles:

The Genesis Enclosure is designed based on the following daily cycles:

- Normal 20
- Heavy 60
- Excessive 75
- Max. starts per hour 7

Consult your Sales Representative if there is a chance you may exceed these amounts.

Speed:

3 meters (10 ft) per minute at full load

Operating Controls:

Keyed Controls: Keyswitch on call stations and platform controls (optional)

Directional Controls: Continuous pressure switches

Control Voltage: 24 VDC

Safety Features:

Safety Nut:

Safety nut automatically engages if drive nut fails. Platform falls less than 13mm (1/2") when safety nut engages. Engaging safety nut trips the safety circuit.

Door Interlocks:

WR500 lock with electric contact prevents the door from opening unless the platform is at landing.

Emergency Stop:

Stops platform travel and sounds audible alarm.

Emergency Operation:

Equipped standard with a manual lowering wheel. Optional battery powered lowering system available.

Finish:

Enclosure Frame & Mast Sides: Extruded aluminum powder coat Silver Moon.

Sidewalls & Mast Cover: Baked powder finish on 16 gauge galvanized steel panels – Silver Moon.

Doors: Baked powder finish on 16 gauge galvanized steel panels – Silver Moon or optional 5mm (3/16") thick clear or smoked grey Plexiglas.

Optional Finishes: Extrusions and panels can be painted any color in the RAL chart.

Hydraulic Drive System: Technical Reference

Platform Sizes:

- Standard
- Mid-size
- Large

For clear platform dimensions, please see page 18.

Rated Load:

340 kg (750 lbs), with a safety factor of 5

Drive System:

Mains Power:

120 VAC single phase on a dedicated 15 amp circuit.
Outside N.A. - 208-240 VAC single phase on a dedicated 16 amp circuit.

Drive Type: Chained Hydraulic (Dual 5/8" ANSI 50 chains)

Standard Motor: 2.2 kW Motor 24V DC: Continuous mains power and auxiliary battery power

Optional Power Supply: 2.2 kW Motor: 24V DC from battery system, continuously charged by buildings mains power (suitable for low usage lifts only).

Daily Cycles:

The Genesis Enclosure is designed based on the following daily cycles:

- Normal 20
- Heavy 60
- Excessive 75
- Max. starts per hour 7

Consult your Sales Representative if there is a chance you may exceed these amounts.

Speed:

5.2 meters (17 ft) per minute at full load

Operating Controls:

Keyed Controls: Keyswitch on call station and platform controls (optional)

Directional Controls: Continuous pressure switches

Control Voltage: 24 VDC

Safety Features:

Safety: Monitored slack chain device. Automatically engages if the drive chain slackens. Platform falls less than 13mm (1/2") when the slack chain safety device engages.

Door Interlocks:

WR500

lock with electric contact prevents door from opening unless platform at landing.

Emergency Stop:

Stops platform travel, illuminates and sounds an audible alarm.

Emergency Operation:

Auxiliary Power System allows the lift to operate in the up and down directions.

Finish:

Enclosure Frame & Mast Sides: Extruded aluminum powder coat Silver Moon.

Sidewalls & Mast Cover: Baked powder finish on 16 gauge galvanized steel panels – Silver Moon.

Doors: Baked powder finish on 16 gauge galvanized steel panels – Silver Moon or optional 5mm (3/16") thick clear or smoked grey Plexiglas.

Optional Finishes: Extrusions and panels can be painted in the large selection of colors from the RAL color chart.

Enclosure Model Loading Diagram Wall and Floor Reactions

| Size | L1 | L2 |
|-----------|---------------|----------------|
| 36" x 54" | 674mm (26.5") | 1222mm (48.1") |
| 36" x 60" | 674mm (26.5") | 1222mm (48.1") |
| 42" x 60" | 750mm (29.5") | 1374mm (54.1") |

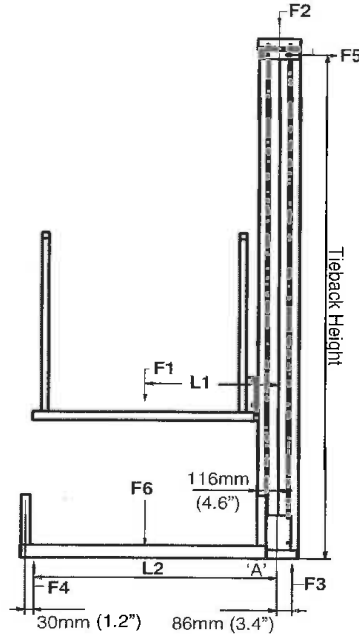

| GENESIS FORCE REACTION CHART | | | | | | | | |
|------------------------------|-------------------|-----------------|-----------------|---------|---------|---------|---------|---------|
| LIFT MODEL | ENCLOSURE WT (lb) | MAST HEIGHT | TIEBACK HEIGHT | F2 (lb) | F3 (lb) | F4 (lb) | F5 (lb) | F6 (lb) |
| 42" | 400 | 1737mm (68.4") | 1643mm (64.7") | 175 | 1270 | 310 | 456 | 400 |
| 60" | 450 | 2194mm (86.4") | 2101mm (82.7") | 215 | 1320 | 342 | 357 | 450 |
| 72" | 500 | 2498mm (98.3") | 2405mm (94.7") | 260 | 1390 | 375 | 312 | 500 |
| 96" | 625 | 3108mm (122.4") | 3015mm (118.7") | 375 | 1540 | 456 | 249 | 625 |
| 120" | 700 | 3718mm (146.4") | 3625mm (142.7") | 450 | 1640 | 506 | 207 | 700 |
| 144" | 800 | 4327mm (170.4") | 4234mm (166.7") | 525 | 1750 | 570 | 177 | 800 |
| 168" | 900 | 4937mm (194.4") | 4844mm (190.7") | 600 | 1870 | 635 | 155 | 900 |

Reactions are based on a 144" mast and a 42" X 60" platform. F1=1000lb.



Authorized Garaventa Lift Representative

15808-AC-DP-EN

© Garaventa Lift. As we are continuously improving our products, specifications outlined in this brochure are subject to change without notice.

www.garaventalift.com